

P r i c e

B o o k



2 0 1 1

**Presto** LIFTS

# Table of Contents

<b>Stackers</b>	
PowerStak	2-3
Lift Stik	4
Manual Foot Operated Stackers	5
Manual Hand Operated Stackers	5
PowerStak Counterweight Stackers	6
Counterweight Stackers	6
Battery Operated Stackers	7
Straddle Stackers	7
Pallet Stackers	8
Non-Straddle Work Positioners	9
Straddle Work Positioners	9
A/C Electric Stackers	10
Hand Crank Mechanical Stackers	10
Drum Stackers	11
Stacker Options	11
<b>Pallet Positioners</b>	
P3 - Presto Pallet Positioner	12
Accuload Positioner	12
<b>Hydraulic Lifts and Tilts</b>	
Standard Duty Scissor Lifts	13
Wide Base Scissor Lifts	14
Tandem Scissor Lifts	15
Wide Base Tandem Scissor Lifts	15
Dual Scissor Lifts	15
Light Duty Manual Scissor Lifts	16
Light Duty Electric Scissor Lifts	16
Portable Manual Scissor Lifts	17
Portable Electric Scissor Lifts	17
Double Scissor Lifts	18
Portable Double Scissor Lifts	18
Post Lift Tables	19
Mechanical Post Lift Tables	19
Hydraulic Cantilever Tables	19
Floor Level Lift & Tilt Tables	20
Floor Level Container Tilters	20
Floor Level Tilters	20
Floor Level Lifts	21
P4 - Floor Level Loader	21
Stationary Container Tilters	22
Portable Container Tilters	22
Standard Tilt Tables	23
Wide Base Tilt Tables	23
Scissor Lift & Tilt Tables	24
Hydraulic Lift & Tilt Options	25
<b>Turntables</b>	
Standard, Floor Mount and Low Profile Turntables	26
<b>Pneumatic Lifts and Tilts</b>	
Pneumatic Scissor Lifts	27
Heavy Duty Pneumatic Scissor Lifts	27
Pneumatic Scissor Lift & Tilt Tables	28
Heavy Duty Pneumatic Scissor Lift & Tilt Tables	28
Pneumatic Scissor Lift & Rotate Tables	29
Heavy Duty Pneumatic Scissor Lift & Rotate Tables	29
Pneumatic Tilt Tables	30
Pneumatic Options	30
<b>Skid Lifters and Pallet Trucks</b>	
Manual and Battery Powered Skid Lifters	31
HPT Hand Pallet Trucks	31
<b>Guidelines</b>	
Select a Stacker	32
Select a Scissor Lift	33
Select a Tilt Table	34
<b>Policies</b>	
Presto Lifts Sales & Limited Warranty Policies	35
Glossary of Terms	36

# PowerStak

## PowerStak Series



Narrow mast and offset design provide workers a clear view with no blind spots.



Adjustable fork carriage allows forks to be quickly repositioned to best accommodate loads (straddle only).

Model Number	Load Capacity	Raised Height	Lowered Height	Dimensions H / W / L	Fork O.D.	Base/Legs I.D./O.D.	Shipping Weight	Price Each
<b>PPS Series - Fork Over - 21" Overall Fork Width - 24" Load Center</b>								
PPS2200-62NFO-21	2200 lbs	62"	3-1/2"	78 x 31-1/2 x 65"	20-1/2"	N/A	1100 lbs	\$5,820
<b>PPS Series - Fork Over - 27" Overall Fork Width - 24" Load Center</b>								
PPS2200-62NFO-27	2200 lbs	62"	3-1/2"	78 x 31-1/2 x 65"	26-3/4"	N/A	1100 lbs	\$5,820
<b>PPS Series - Adjustable Base - Straddle (40-50" I.D.) - 24" Load Center</b>								
PPS2200-62NAS	2200 lbs	62"	2-5/8"	79 x 48-58 x 68"	12-1/2" - 26-3/4"	40-50" / 48-58"	1200 lbs	\$5,890
PPS2200-101AS	2200 lbs	101"	2-5/8"	73 x 48-58 x 73"	12-1/2" - 26-3/4"	40-50" / 48-58"	1405 lbs	\$7,250
PPS2200-125AS	2200 lbs	125"	2-5/8"	83 x 48-58 x 73"	12-1/2" - 26-3/4"	40-50" / 48-58"	1445 lbs	\$7,830
PPS2200-150AS	2200 lbs	150"	2-5/8"	99 x 48-58 x 73"	12-1/2" - 26-3/4"	40-50" / 48-58"	1545 lbs	\$8,730

### Features

- 24 volt DC/700 watt drive motor
- 10" x 3" Polyurethane drive wheel
- Polyurethane load wheels
- Adjustable welded steel forks, 6" wide x 2" thick x 42" long (NFO models have fixed forks)
- 2 x 12 volt amp/hr batteries
- 15 amp internal 115V charger
- Battery discharge indicator
- E-Stop emergency stop switch
- Safety key switch

### Options for PPS2200 models:

- Load Backrest.....\$235
- Forged Steel Forks.....\$415
- Rubber Drive Wheel.....\$300
- Non-Marking Rubber
- Drive Wheel.....\$365
- Spiral Cell Marine Battery 2 x 50 amp/hr.....\$685
- Battery - 12 volt 70 amp AGM sealed battery.....\$415

**Note:** Not all options are available for all models; please contact Sales before ordering.



Ergonomic handle with comfort-grip controls and switch redundancy for left- or right-hand operation.



Auto-reversing "belly bump" switch protects against operator accidents while working in tight quarters.



Fork-Over model shown

Straddle model shown

## Heavy Duty PowerStak

Model Number	Load Capacity	Raised Height	Lowered Height	Dimensions H / W / L	Fork O.D.	Base/Legs I.D./O.D.	Shipping Weight	Price Each
<b>PPS Series - Fixed Base - Straddle (50" I.D.) - 24" Load Center</b>								
PPS3000-125FS	3000 lbs	125"	2-3/32"	83 x 58 x 77"	8" - 26-3/4"	50"/58"	2000 lbs	\$9,680

### Features

- 24 volt DC/1000 watt drive motor
- 10" x 4" polyurethane drive wheel
- Tandem polyurethane load wheels
- Adjustable forged steel forks, 4" wide x 2" thick x 42" long
- 2 x 12 volt 150 amp/hr batteries
- 25 amp internal 115V charger
- Hour meter with battery discharge indicator
- E-Stop emergency stop switch
- Safety key switch



Tandem polyurethane load wheels



Forged forks



PPS3000-125FS shown.

## PowerStak LITE

Model Number	Load Capacity	Raised Height	Lowered Height	Dimensions H / W / L	Fork O.D.	Base/Legs I.D./O.D.	Shipping Weight	Price Each
<b>PPS Series - Fork Over - 21" Overall Fork Width - 24" Load Center</b>								
PPS1500-62NFO-21	1500 lbs	62"	3-3/8"	78 x 29 x 66"	20-1/2"	N/A	805 lbs	\$4,860
<b>PPS Series - Fork Over - 27" Overall Fork Width - 24" Load Center</b>								
PPS1500-62NFO-27	1500 lbs	62"	3-3/8"	78 x 29 x 66"	20-3/4"	N/A	805 lbs	\$4,860
<b>PPS Series - Adjustable Base - Straddle (38-52" I.D.) - 24" Load Center</b>								
PPS1500-62NAS	1500 lbs	62"	2-5/8"	79 x 46-60 x 69"	12-1/2" / 26-3/4"	40-50" / 48-58"	982 lbs	\$4,930



PPS1500-62NAS shown.



PPS1500-62NFO shown.

### Features

- 24 volt DC/350 watt drive motor
- 7" x 2" polyurethane drive wheel
- Polyurethane load wheels
- Adjustable welded steel forks, 6" wide x 2" thick x 42" long (NFO) models have fixed forks
- 2 x 12 volt 55 amp/hr batteries
- 15 amp internal 115V charger
- Battery discharge indicator
- E-Stop emergency stop switch
- Safety key switch

Fully powered PowerStak Counterweight stacker available on page 6

# Lift Stik

## Lift Stik Series

Model Number	Load Capacity	Raised Height	Lowered Height	Dimensions H / W / L	Platform W / L	Lifting Speed*	Power Unit	On Board Charger	Shipping Weight	Price Each
<b>Lift Stik Series</b>										
PLS52-185	185 lbs	56"	5"	63 x 23-1/2 x 31"	23-1/2 x 18-1/2"	17 sec	24DC	115 Volt	86 lbs	\$3,080
PLS60-220	220 lbs	65"	5-1/8"	76 x 23-1/2 x 33"	23-1/2 x 18-1/2"	20 sec	24DC	115 Volt	100 lbs	\$4,220
PLS48-450	445 lbs	52"	4-1/8"	63 x 22 x 40"	22 x 23-1/2"	22 sec	24DC	115 Volt	142 lbs	\$5,200

\*Speed of unit without load

### Features

There has never been a more versatile lifter/transporter than the Lift Stik. Capacities range from 185-450 lbs.

- Continued lifting chain provides two vertical travel speeds
- Smooth starts and stops
- Precise load positioning with zero drift
- No risk of hydraulic fluid leaks so it can be used in light industrial, laboratory, and even office applications as well as:

**Stock Rooms**  
**Test and Measurement Stations**  
**Office Supply Rooms**  
**Electronic Assembly Areas - Computer and Server Rooms**

- Loads are centrally and evenly distributed over all 4 wheels for maximum stability
- Control unit can be easily reached without removing your hands from the steering handle, which is detachable and can be used remotely
- Two-speed function, both up and down
- Battery charger status indicator is easily visible
- Ball bearing wheels roll easily on all surfaces
- Equipped with toeguards
- The mast and the motor covers are sealed
- Mechanical overload protection
- All models come standard with a platform mounted on the forks



\*Optional attachments shown below. Contact Presto Sales for pricing and to confirm the suitability of the application.

### Lift Stik Options

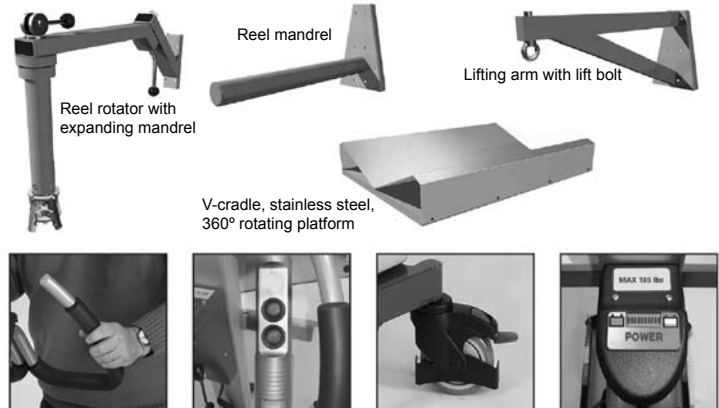

Oversized ergonomic "sponge grip" handle provides operator comfort and a variety of grip options

Push-button remote control is mounted conveniently on the handle and has a coiled cord for remote operation

Wheels feature brake locks for safety while loading or unloading, steering lock for straight-line travel, and protective toe guards

High-visibility status indicator shows power information at a glance. On-board charger provides quick battery recharging

Highlighted models are AIS (Always In Stock) and ship within one week.

# Manual Stackers

## Foot-Operated Stackers

Model Number	Load Capacity	Raised Height	Lowered Height	Dimensions H / W / L	Base Legs I.D. / O.D.	Wheel Dia. Front/Rear	Shipping Weight	Price Each
<b>M100 Series - Platform (21" W x 24" L) - 15" Load Center</b>								
M152	1000 lbs	52"	5-1/4"	66 x 25 x 38"	15" / 21"	5" / 4"	270 lbs	\$1,440
M166	1000 lbs	66"	5-1/4"	80 x 25 x 38"	15" / 21"	5" / 4"	290 lbs	\$1,570
M178	1000 lbs	78"	5-1/4"	92 x 25 x 38"	15" / 21"	5" / 4"	300 lbs	\$1,720
<b>M300 Series - Platform (32" W x 30" L) - 18" Load Center</b>								
M352	1000 lbs	52"	5-1/4"	66 x 33 x 44"	24" / 30"	5" / 4"	350 lbs	\$1,690
M366	1000 lbs	66"	5-1/4"	80 x 33 x 44"	24" / 30"	5" / 4"	370 lbs	\$1,840
M378	1000 lbs	78"	5-1/4"	92 x 33 x 44"	24" / 30"	5" / 4"	390 lbs	\$1,980
<b>M200 Series - Adjustable 25" Forks (Non-Straddle) - 15" Load Center</b>								
M252	1000 lbs	52"	5-1/4"	66 x 27 x 42"	15" / 21"	5" / 4"	340 lbs	\$1,620
M266	1000 lbs	66"	5-1/4"	80 x 27 x 42"	15" / 21"	5" / 4"	360 lbs	\$1,760
M278	1000 lbs	78"	5-1/4"	92 x 27 x 42"	15" / 21"	5" / 4"	390 lbs	\$1,910
<b>M300 Series - Adjustable 30" Forks (Non-Straddle) - 18" Load Center</b>								
M452	1000 lbs	50"	3-1/4"	66 x 33 x 49"	26" / 32"	5" / 4"	370 lbs	\$1,640
M466	1000 lbs	64"	3-1/4"	80 x 33 x 49"	26" / 32"	5" / 4"	390 lbs	\$1,790
M478	1000 lbs	76"	3-1/4"	92 x 33 x 49"	26" / 32"	5" / 4"	410 lbs	\$1,930

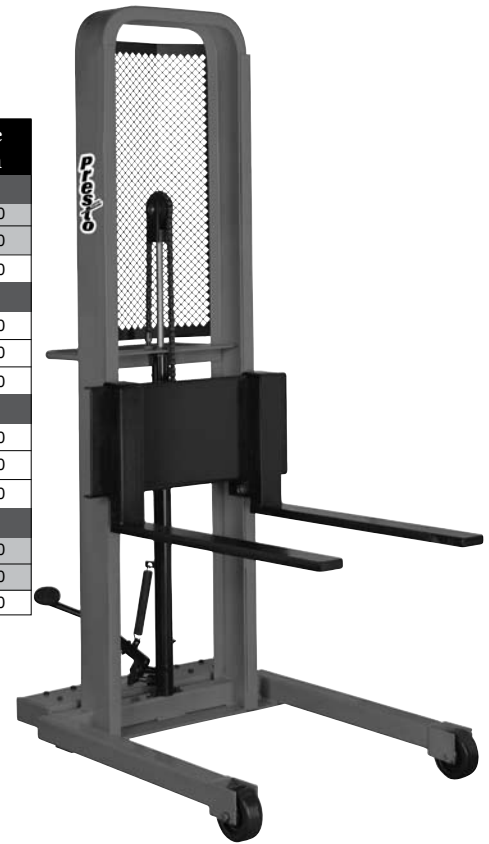

### Features

- 1000 lb capacity at 15" and 18" load centers
- Lifting heights - 50" through 78"
- 1" thick x 3" wide adjustable solid steel forks
- Forks adjust from 6-1/2" to 26-1/2" O.D.
- 12" high fork backs on non-straddle models
- 14" high fork backs on straddle models
- Foot-operated pump with tip-toe release
- Lift rise approximately 1-1/8" per stroke
- Perforated metal screen
- Foot-operated floor lock
- Leaf-type chain with 8250 lb yield point
- High-impact, floor-saving phenolic wheels

## Hand-Operated Stackers

Model Number	Load Capacity	Raised Height	Lowered Height	Dimensions H / W / L	Base Legs I.D. / O.D.	Wheel Dia. Front/Rear	Shipping Weight	Price Each
<b>M800 Series - Adjustable 30" Forks (Straddle) - 18" Load Center</b>								
M852-2000	2000 lbs	50"	3-1/4"	66 x 33 x 51"	26" / 32"	5" / 5"	460 lbs	\$2,610
M866-2000	2000 lbs	64"	3-1/4"	80 x 33 x 51"	26" / 32"	5" / 5"	480 lbs	\$2,630
M878-2000	2000 lbs	76"	3-1/4"	92 x 33 x 51"	26" / 32"	5" / 5"	500 lbs	\$3,040

### Features

- 2000 lb capacity at 18" load center
- Lifting heights - 50" through 76"
- Slip-on 32" x 30" platform available
- 1-1/2" thick x 3" wide adjustable solid steel forks
- Forks adjust from 6-1/2" to 26-1/2" O.D.
- 14" high fork backs
- Hand-operated pump (2 cycle) with hand release
- Lift rise approximately 1/2" per stroke
- Perforated metal screen
- Foot-operated floor lock
- Dual leaf-type chain with 8250 lb yield point
- High-impact, floor-saving phenolic wheels

Stacker options on page 11

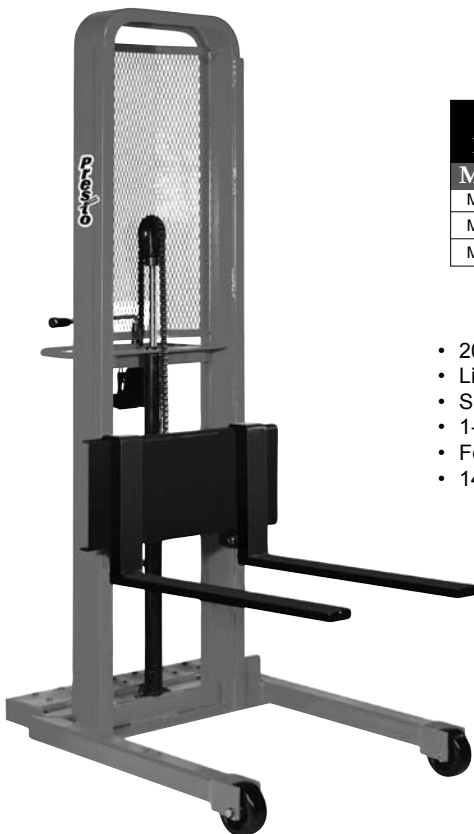

Highlighted models are AIS (Always In Stock) and ship within one week.

# Counterweight Stackers



## PowerStak Counterweight Stackers

Model Number	Load Capacity	Raised Height	Lowered Height	Dimensions H / W / L	Wheel Diameter	Shipping Weight	Price Each
<b>PPS Series Counterweight - 15" Load Center</b>							
PPS1100-62-CB	1100 lbs	62"	1"	81 x 32-1/4 x 78-3/8"	6-1/4"	1797 lbs	\$6,500

### Features

- 1100 lb capacity
- 15" load center
- Not for use with pallets or loads greater than 30" in depth
- 62" lifting height
- "Belly Bump" auto-reverse switch
- Fully powered drive with 24VDC 700W drive motor
- Two 12V 100 amp/hr batteries
- 110V 15 amp built-in charger
- 1" thick x 3" wide forks
- Forks adjust from 6-1/3" to 23-3/5"

## Counterweight Stackers

Model Number	Load Capacity	Raised Height	Lowered Height	Dimensions H / W / L	Wheel Diameter	Shipping Weight	Price Each
<b>CW Series - Adjustable 25" Forks - 13" Load Center</b>							
C62A-200	200 lbs	62"	1"	80 x 27 x 36"	5" x 5"	750 lbs	\$3,350
C62A-400	400 lbs	62"	1"	80 x 27 x 36"	5" x 5"	900 lbs	\$3,450
C62A-600	600 lbs	62"	1"	80 x 27 x 36"	5" x 5"	1000 lbs	\$3,510
C62A-800	800 lbs	62"	1"	80 x 27 x 36"	5" x 5"	1100 lbs	\$3,590
C62A-1000	1000 lbs	62"	1"	80 x 27 x 36"	5" x 5"	1200 lbs	\$3,650
C74A-200	200 lbs	74"	1"	92 x 27 x 36"	5" x 5"	775 lbs	\$3,630
C74A-400	400 lbs	74"	1"	92 x 27 x 36"	5" x 5"	925 lbs	\$3,730
C74A-600	600 lbs	74"	1"	92 x 27 x 36"	5" x 5"	1025 lbs	\$3,790
C74A-800	800 lbs	74"	1"	92 x 27 x 36"	5" x 5"	1125 lbs	\$3,860
C74A-1000	1000 lbs	74"	1"	92 x 27 x 36"	5" x 5"	1225 lbs	\$3,930
<b>CW Series - Adjustable 30" Forks - 15" Load Center</b>							
C62A-15LC	1000 lbs	62"	1"	80 x 27 x 41"	5" x 5"	1450 lbs	\$4,200
C74A-15LC	1000 lbs	74"	1"	92 x 27 x 41"	5" x 5"	1475 lbs	\$4,340

Overall length (including forks) on C62A & C74A is 61" and the C62A-15LC and C74A-15LC length is 66".  
Counterweight (ballast) is included in pricing and in shipping weights.

### Features

- Up to 1000 lb capacity
- 13" & 15" load centers
- Lifting heights - 62" & 74"
- Lifting speed 5" per second
- Forks adjust from 6-1/2" to 20" O.D. between wheels
- 15-1/2" high fork backs
- Heavy-duty C100 foot operated floor lock
- No outriggers
- Heavy-duty 12V battery
- 1" thick x 3" wide adjustable solid steel forks
- Hinged door with capacity display
- LED dash mount - diagnostic display
- 3 position "Comfort Cushion" push handle
- Custom micro-processor charger
- Quick-connect battery cables (no tools required)

All options and attachments require application information. Please contact Sales.



Highlighted models are AIS (Always In Stock) and ship within one week.

# Battery Stackers

## Battery-Operated Stackers

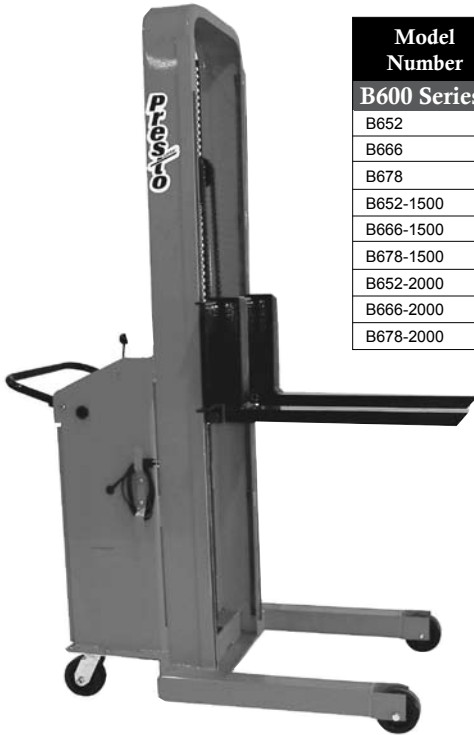

Model Number	Load Capacity	Raised Height	Lowered Height	Dimensions H / W / L	Base Legs I.D. / O.D.	Wheel Dia. Front/Rear	Shipping Weight	Price Each
<b>B600 Series - Adjustable 25" Forks (Non-Straddle) - 15" Load Center</b>								
B652	1000 lbs	52"	5-1/4"	67 x 27 x 49"	15" / 21"	5" / 5"	500 lbs	\$2,690
B666	1000 lbs	66"	5-1/4"	81 x 27 x 49"	15" / 21"	5" / 5"	520 lbs	\$2,760
B678	1000 lbs	78"	5-1/4"	93 x 27 x 49"	15" / 21"	5" / 5"	540 lbs	\$2,990
B652-1500	1500 lbs	52"	5-1/4"	67 x 27 x 49"	15" / 22"	5" / 5"	530 lbs	\$2,840
B666-1500	1500 lbs	66"	5-1/4"	81 x 27 x 49"	15" / 22"	5" / 5"	550 lbs	\$2,980
B678-1500	1500 lbs	78"	5-1/4"	93 x 27 x 49"	15" / 22"	5" / 5"	570 lbs	\$3,130
B652-2000	2000 lbs	52"	5-1/4"	67 x 27 x 49"	20" / 26"	5" / 5"	550 lbs	\$2,990
B666-2000	2000 lbs	66"	5-1/4"	81 x 27 x 49"	20" / 26"	5" / 5"	570 lbs	\$3,130
B678-2000	2000 lbs	78"	5-1/4"	93 x 27 x 49"	20" / 26"	5" / 5"	590 lbs	\$3,200

### Features

- 1000 - 2000 lb capacity
- 15" load center
- Lifting heights - 52" through 78"
- 1" thick x 3" wide adjustable solid steel forks on 1000 lb & 1500 lb units
- 1-1/2" thick x 3" wide adjustable solid steel forks on 2000 lb units
- Forks adjust from 6-1/2" to 26-1/2" O.D.
- 12" high fork backs
- Lifting speed 5" per second
- Fixed base
- Heavy-duty 12V battery
- Foot-operated floor lock
- Leaf-type chain with 8250 lb yield point
- Optional 24" x 24" slip-on platform
- Floor-saving phenolic wheels
- Perforated metal screen
- LED dash mount -- diagnostic display
- 3-position "Comfort Cushion" push handle
- Custom micro-processor charger
- Quickconnect battery cables (no tools required)

## Straddle Stackers



Model Number	Load Capacity	Raised Height	Lowered Height	Dimensions H / W / L	Base Legs I.D. / O.D.	Wheel Dia. Front/Rear	Shipping Weight	Price Each
<b>B800 Series - 20" Load Center</b>								
B862-1500	1500 lbs	62"	2"	80 X 32 X 54"	26" / 32"	5" / 4"	625 lbs	\$2,980
B874-1500	1500 lbs	74"	2"	92 X 32 X 54"	26" / 32"	5" / 4"	650 lbs	\$3,230
B886-1500	1500 lbs	86"	2"	104 X 32 X 54"	26" / 32"	5" / 4"	670 lbs	\$3,400
B862-2000	2000 lbs	62"	2-1/2"	80 X 32 X 54"	26" / 32"	5" / 4"	635 lbs	\$3,150
B874-2000	2000 lbs	74"	2-1/2"	92 X 32 X 54"	26" / 32"	5" / 4"	660 lbs	\$3,400
B886-2000	2000 lbs	86"	2-1/2"	104 X 32 X 54"	26" / 32"	5" / 4"	680 lbs	\$3,550
<b>BT800 Series - 20" Load Center</b>								
BT894-1500	1500 lbs	94"	2-1/2"	119/74 X 38 X 55"	32" / 38"	5" / 4"	860 lbs	\$3,850
BT8107-1500	1500 lbs	107"	2-1/2"	133/81 X 38 X 55"	32" / 38"	5" / 4"	920 lbs	\$4,050
BT8127-1500	1500 lbs	127"	2-1/2"	154/93 X 38 X 55"	32" / 38"	5" / 4"	970 lbs	\$4,440
BT894-2000	2000 lbs	94"	2-1/2"	119/74 X 38 X 55"	32" / 38"	5" / 4"	880 lbs	\$4,050
BT8107-2000	2000 lbs	107"	2-1/2"	113/81 X 38 X 55"	32" / 38"	5" / 4"	930 lbs	\$4,290
BT8127-2000	2000 lbs	127"	2-1/2"	154/92 X 38 X 55"	32" / 38"	5" / 4"	980 lbs	\$4,720

Units over 93" in height will be shipped in the horizontal position.

### Features

- 1500 - 2000 lb capacity
- 20" load center
- Lifting heights - 62" through 127"
- 1" thick x 3" wide x 30" long adjustable solid steel forks on 1500 lb B800 series
- 1-1/2" thick x 3" wide x 30" long adjustable solid steel forks on BT800 & 2000 lb B800 series
- Forks adjust from 6-1/2" to 26-1/2" O.D. on B800 series
- 15-1/2" high fork backs on 1500 lb units
- 15" high fork backs on 2000 lb units
- 14" high fork backs on BT series units
- Fixed and telescopic mast
- Turning radius with 40" load:
  - 85" aisle for B800 series
  - 87" aisle for BT800 series
 (Allows for 12" of operator clearance)
- Hand-operated floor lock
- Flow control valve for smooth lowering
- Lifting speed 5" per second
- Fixed base
- Heavy-duty 12V battery
- Custom micro-processor charger
- Optional fifth wheel for greater mobility
- Dual leaf-type chains with 8250 lb yield point
- High-impact, floor-saving phenolic load wheels

Stacker options on page 11



# Pallet Stackers

## Pallet Stackers

Model Number	Load Capacity	Raised Height	Lowered Height	Dimensions H / W / L	Base Legs I.D. / O.D.	Wheel Dia. Front/Rear	Shipping Weight	Price Each
<b>PS Series - 42" I.D. Straddle - 24" Load Center</b>								
PS262	2000 lbs	62"	2-1/2"	82 x 48 x 70"	42" / 48"	5" / 4"	875 lbs	\$4,140
PS274	2000 lbs	72"	2-1/2"	94 x 48 x 70"	42" / 48"	5" / 4"	925 lbs	\$4,250
PS286	2000 lbs	86"	2-1/2"	106 x 48 x 70"	42" / 48"	5" / 4"	975 lbs	\$4,350
PS2762	2700 lbs	60"	2-1/2"	84 x 48 x 70"	42" / 48"	5" / 4"	1000 lbs	\$4,350
PS2774	2700 lbs	72"	2-1/2"	96 x 48 x 70"	42" / 48"	5" / 4"	1045 lbs	\$4,510
<b>PS50 Series - 50" I.D. Straddle - 24" Load Center</b>								
PS62-50	1500 lbs	62"	2-1/2"	82 x 56 x 70"	50" / 56"	5" / 4"	875 lbs	\$3,900
PS74-50	1500 lbs	74"	2-1/2"	94 x 56 x 70"	50" / 56"	5" / 4"	925 lbs	\$4,030
PS86-50	1500 lbs	86"	2-1/2"	106 x 56 x 70"	50" / 56"	5" / 4"	975 lbs	\$4,200
PS262-50	2000 lbs	62"	2-1/2"	82 x 56 x 70"	50" / 56"	5" / 4"	900 lbs	\$4,000
PS274-50	2000 lbs	74"	2-1/2"	94 x 56 x 70"	50" / 56"	5" / 4"	975 lbs	\$4,350
PS286-50	2000 lbs	86"	2-1/2"	106 x 56 x 70"	50" / 56"	5" / 4"	1000 lbs	\$4,510
PS2762-50	2700 lbs	60"	2-1/2"	84 x 56 x 70"	50" / 56"	5" / 4"	1025 lbs	\$4,510
PS2774-50	2700 lbs	72"	2-1/2"	96 x 56 x 70"	50" / 56"	5" / 4"	1070 lbs	\$4,650
<b>PSA Series - Adjustable Base - Straddle (35" I.D. to 50" I.D.) - 24" Load Center</b>								
PSA62	1500 lbs	62"	2-1/2"	82 x 41-56 x 72"	35-50" / 41-56"	5" / 5"	995 lbs	\$4,170
PSA74	1500 lbs	74"	2-1/2"	94 x 41-56 x 72"	35-50" / 41-56"	5" / 5"	1045 lbs	\$4,340
PSA86	1500 lbs	86"	2-1/2"	106 x 41-56 x 72"	35-50" / 41-56"	5" / 5"	1095 lbs	\$4,510
PSA262	2000 lbs	62"	2-1/2"	82 x 41-56 x 72"	35-50" / 41-56"	5" / 5"	1000 lbs	\$4,280
PSA274	2000 lbs	74"	2-1/2"	94 x 41-56 x 72"	35-50" / 41-56"	5" / 5"	1045 lbs	\$4,650
PSA286	2000 lbs	86"	2-1/2"	106 x 41-56 x 72"	35-50" / 41-56"	5" / 5"	1100 lbs	\$4,810
PSA2762	2700 lbs	60"	2-1/2"	84 x 41-56 x 72"	35-50" / 41-56"	5" / 5"	1145 lbs	\$4,800
PSA2774	2700 lbs	72"	2-1/2"	96 x 41-56 x 72"	35-50" / 41-56"	5" / 5"	1175 lbs	\$4,950
<b>PST Series - 42" I.D. Straddle - Telescoping Mast - 24" Load Center</b>								
PST294	2000 lbs	94"	2-1/2"	119/73 x 48 x 71"	42-48"	5" / 4"	1000 lbs	\$4,960
PST2107	2000 lbs	107"	2-1/2"	133/81 x 48 x 71"	42-48"	5" / 4"	1050 lbs	\$5,130
PST2127	2000 lbs	127"	2-1/2"	155/93 x 48 x 71"	42-48"	5" / 4"	1100 lbs	\$5,190
PST2144	2000 lbs	144"	2-1/2"	169/99 x 48 x 71"	42-48"	5" / 4"	1150 lbs	\$5,850
PST2794	2700 lbs	94"	2-1/2"	119/75 x 48 x 71"	42-48"	5" / 4"	1190 lbs	\$5,260
PST27107	2700 lbs	107"	2-1/2"	133/81 x 48 x 71"	42-48"	5" / 4"	1240 lbs	\$5,430
PST27127	2700 lbs	127"	2-1/2"	156/94 x 48 x 71"	42-48"	5" / 4"	1290 lbs	\$5,970
<b>PST50 Series - 50" I.D. Straddle - Telescoping Mast - 24" Load Center</b>								
PST294-50	2000 lbs	94"	2-1/2"	119/73 x 56 x 71"	50-56"	5" / 4"	1010 lbs	\$5,110
PST2107-50	2000 lbs	107"	2-1/2"	133/81 x 56 x 71"	50-56"	5" / 4"	1060 lbs	\$5,260
PST2127-50	2000 lbs	127"	2-1/2"	155/93 x 56 x 71"	50-56"	5" / 4"	1110 lbs	\$5,410
PST2144-50	2000 lbs	144"	2-1/2"	169/99 x 56 x 71"	50-56"	5" / 4"	1170 lbs	\$5,890
PST2794-50	2700 lbs	94"	2-1/2"	119/75 x 56 x 71"	50-56"	5" / 4"	1200 lbs	\$5,420
PST27107-50	2700 lbs	107"	2-1/2"	133/81 x 56 x 71"	50-56"	5" / 4"	1250 lbs	\$5,570
PST27127-50	2700 lbs	127"	2-1/2"	156/94 x 56 x 71"	50-56"	5" / 4"	1300 lbs	\$6,090
<b>PSTA Series - Adjustable Base - Straddle (35" I.D. to 50" I.D.) - 24" Load Center</b>								
PSTA294	2000 lbs	94"	2-1/2"	119/73 x 41-56 x 73"	35-50" / 41-56"	5" / 5"	1150 lbs	\$5,430
PSTA2107	2000 lbs	107"	2-1/2"	133/80 x 41-56 x 73"	35-50" / 41-56"	5" / 5"	1200 lbs	\$5,550
PSTA2127	2000 lbs	127"	2-1/2"	154/92 x 41-56 x 73"	35-50" / 41-56"	5" / 5"	1250 lbs	\$5,960
PSTA2794	2700 lbs	94"	2-1/2"	120/75 x 41-56 x 73"	35-50" / 41-56"	5" / 5"	1400 lbs	\$5,710
PSTA27107	2700 lbs	107"	2-1/2"	133/81 x 41-56 x 73"	35-50" / 41-56"	5" / 5"	1450 lbs	\$5,850
PSTA27127	2700 lbs	127"	2-1/2"	155/93 x 41-56 x 73"	35-50" / 41-56"	5" / 5"	1500 lbs	\$6,160

Units over 93" in height will be shipped in the horizontal position.

### Features

- 1500 - 2700 lb capacity
- 24" load centers
- Fixed or adjustable base
- Lifting heights - 62" through 144"
- Fixed and telescopic masts
- Hand-operated floor lock
- 1-1/2" thick x 3" wide x 36" long adjustable solid steel forks (1500 & 2000 lb capacities)
- 1-1/2" thick x 4" wide x 36" long adjustable solid steel forks (2700 lb capacities)
- Lifting speed 4" per second for 1500 & 2000 lb lifts
- Lifting speed 2" per second for 2700 lb lifts
- Heavy-duty 12V battery
- Custom micro-processor charger
- Fifth wheel for greater mobility
- Dual leaf-type chains with 8250 lb yield point
- Dual roller chain for 2700 lb lift
- Forks adjust from 6-1/2" to 30" O.D.
- 14" high fork backs
- Turning radius with 48" load:
  - 106" aisle with 42" I.D. base
  - 110" aisle with 50" I.D. base
  - 112" aisle with adjustable base @ 50" I.D.

Stacker options on page 11

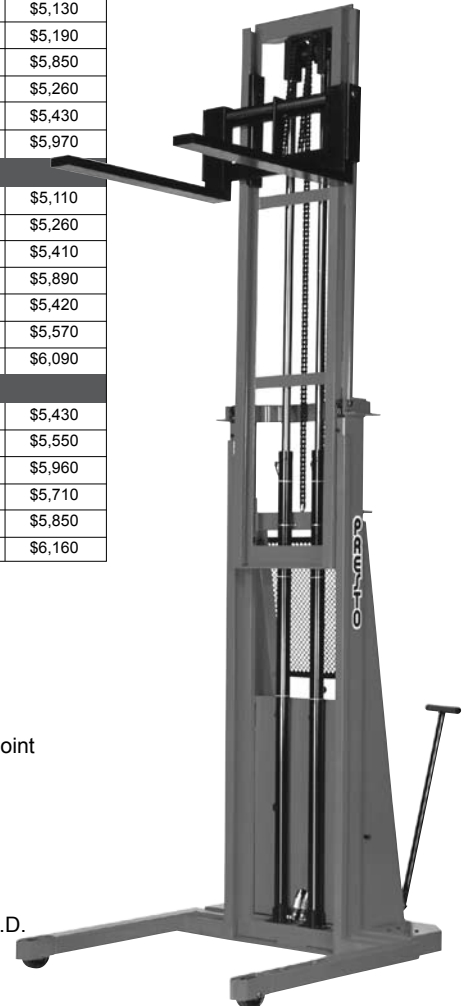

# Work Positioners

## Non-Straddle Work Positioners



Model Number	Load Capacity	Raised Height	Lowered Height	Dimensions H / W / L	Base Legs I.D. / O.D.	Wheel Dia. Front/Rear	Shipping Weight	Price Each
<b>WP Series - Non-Straddle - 24" Load Center</b>								
WP36-20	2000 lbs	36"	3-1/4"	60 x 28 x 65"	14" / 26-1/2"	3" / 8"	710 lbs	\$4,050
WP48-20	2000 lbs	48"	3-1/4"	72 x 28 x 65"	14" / 26-1/2"	3" / 8"	770 lbs	\$4,420
WP60-20	2000 lbs	60"	3-1/4"	84 x 28 x 65"	14" / 26-1/2"	3" / 8"	820 lbs	\$4,580
WP36-30	3000 lbs	36"	3-1/4"	60 x 28 x 65"	14" / 26-1/2"	3" / 8"	760 lbs	\$4,380
WP48-30	3000 lbs	48"	3-1/4"	72 x 28 x 65"	14" / 26-1/2"	3" / 8"	800 lbs	\$4,540
WP60-30	3000 lbs	60"	3-1/4"	84 x 28 x 65"	14" / 26-1/2"	3" / 8"	850 lbs	\$4,910

For use with open bottom skids only.  
Not for use with closed bottom pallets.

### Features

- 2000 - 3000 lb capacity
- 24" load centers
- Lifting heights - 36" through 60"
- Fixed mast and base
- 2" thick x 6-1/4" wide x 42" long fixed steel forks
- 17" high fork carriage
- 14" fork I.D. & 26-1/2" fork O.D.
- 3-1/4" lowered height
- Steering wheel for greater mobility
- Lifting speed 2" per second for 3000 lb capacity units
- Heavy-duty 12V deep cycle battery
- Custom micro-processor charger
- Hand-operated floor lock
- Nylon front load wheels
- Polyurethane rear wheels
- Optional slip-on platforms available

## Straddle Work Positioners

Model Number	Load Capacity	Raised Height	Lowered Height	Dimensions H / W / L	Base Legs I.D. / O.D.	Wheel Dia. Front/Rear	Shipping Weight	Price Each
<b>WPS42 Series - 42" I.D. - 24" Load Center</b>								
WPS4236-20	2000 lbs	36"	2"	59 x 48 x 65"	42" / 48"	5" / 8"	720 lbs	\$4,050
WPS4248-20	2000 lbs	48"	2"	71 x 48 x 65"	42" / 48"	5" / 8"	745 lbs	\$4,380
WPS4260-20	2000 lbs	60"	2"	83 x 48 x 65"	42" / 48"	5" / 8"	770 lbs	\$4,830
WPS4236-30	3000 lbs	36"	2"	59 x 48 x 65"	42" / 48"	5" / 8"	750 lbs	\$4,580
WPS4248-30	3000 lbs	48"	2"	71 x 48 x 65"	42" / 48"	5" / 8"	775 lbs	\$4,750
WPS4260-30	3000 lbs	60"	2"	83 x 48 x 65"	42" / 48"	5" / 8"	800 lbs	\$4,900
<b>WPS50 Series - 50" I.D. - 24" Load Center</b>								
WPS5036-20	2000 lbs	36"	2"	59 x 56 x 65"	42" / 48"	5" / 8"	730 lbs	\$4,220
WPS5048-20	2000 lbs	48"	2"	71 x 56 x 65"	42" / 48"	5" / 8"	755 lbs	\$4,580
WPS5060-20	2000 lbs	60"	2"	83 x 56 x 65"	42" / 48"	5" / 8"	780 lbs	\$4,760
WPS5036-30	3000 lbs	36"	2"	59 x 56 x 65"	42" / 48"	5" / 8"	760 lbs	\$4,480
WPS5048-30	3000 lbs	48"	2"	71 x 56 x 65"	42" / 48"	5" / 8"	785 lbs	\$4,760
WPS5060-30	3000 lbs	60"	2"	83 x 56 x 65"	42" / 48"	5" / 8"	810 lbs	\$5,060

For use with wooden closed bottom pallets, double sided pallets and open bottom skids.

### Features

- 2000 - 3000 lb capacity
- 24" load centers
- Lifting heights - 36" through 60"
- Fixed mast
- Fixed base
- 2" thick x 6-1/4" wide x 42" long fixed steel forks
- 17" high fork carriage
- 14" fork I.D. & 26-1/2" fork O.D.
- 2" lowered height
- Steering wheel for greater mobility
- Lifting speed 4" per second for 2000 lb capacity units
- Lifting speed 2" per second on 3000 lb capacity units
- Heavy-duty 12V battery
- Custom micro-processor charger
- Hand-operated floor lock
- Phenolic front load wheels
- Polyurethane rear wheels
- Optional slip-on platforms available



Stacker options on page 11

# Specialty Stackers

## A/C Electric Stackers

Model Number	Load Capacity	Raised Height	Lowered Height	Dimensions H / W / L	Base Legs I.D. / O.D.	Wheel Dia. Front/Rear	Shipping Weight	Price Each
<b>EPF Series - Portable - 30" Forks - 18" Load Center</b>								
EPF752	1000 lbs	52"	5-1/4"	66 x 31 x 49"	24" / 30"	5" / 4"	445 lbs	\$3,160
EPF766	1000 lbs	66"	5-1/4"	80 x 31 x 49"	24" / 30"	5" / 4"	465 lbs	\$3,330
EPF778	1000 lbs	78"	5-1/4"	92 x 31 x 49"	24" / 30"	5" / 4"	485 lbs	\$3,490
<b>ESF Series - Stationary - 30" Forks - 18" Load Center</b>								
ESF750	1000 lbs	50"	3-1/4"	64 x 30 x 49"	24" / 30"	N/A	425 lbs	\$3,230
ESF764	1000 lbs	64"	3-1/4"	78 x 30 x 49"	24" / 30"	N/A	445 lbs	\$3,400
ESF776	1000 lbs	76"	3-1/4"	90 x 30 x 49"	24" / 30"	N/A	465 lbs	\$3,350
ESF782	1000 lbs	82"	3-1/4"	96 x 30 x 49"	24" / 30"	N/A	475 lbs	\$3,900
ESF788	1000 lbs	88"	3-1/4"	105 x 30 x 49"	24" / 30"	N/A	485 lbs	\$4,070
ESF794	1000 lbs	94"	3-1/4"	108 x 30 x 49"	24" / 30"	N/A	565 lbs	\$4,260
ESF7106	1000 lbs	106"	3-1/4"	120 x 40 x 49"	34" / 40"	N/A	605 lbs	\$4,410
ESF7118	1000 lbs	118"	3-1/4"	132 x 40 x 49"	34" / 40"	N/A	635 lbs	\$4,630
<b>EPFT Series - Portable - 30" Forks - 18" Load Center</b>								
EPFT796	1000 lbs	94"	5-1/4"	112/67 x 41 x 52"	34" / 40"	5" / 5"	640 lbs	\$4,680
EPFT7110	1000 lbs	110"	5-1/4"	133/80 x 41 x 52"	34" / 40"	5" / 5"	670 lbs	\$4,850
EPFT7130	1000 lbs	130"	5-1/4"	155/92 x 40 x 52"	34" / 40"	5" / 5"	735 lbs	\$5,170

Units over 93" in height will be shipped in the horizontal position.

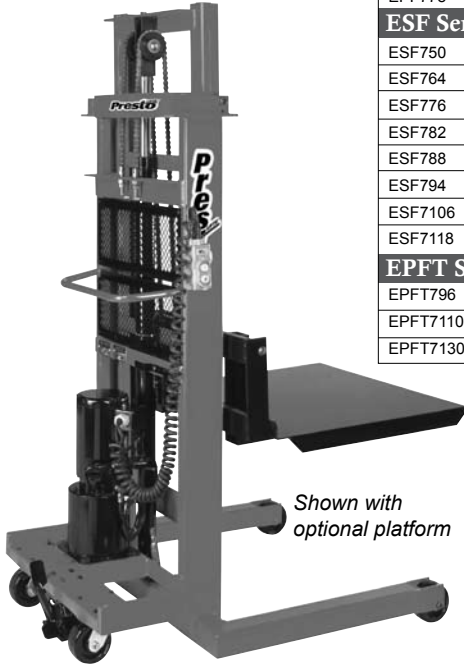

### Features

- 1000 lb capacity
- 18" load centers
- Lifting heights - 52" through 130"
- Fixed and telescopic masts
- Stationary and portable units
- Lifting speed 4" per second
- Standard 1 HP 115/1/60 motor
- 1" thick x 3" wide x 30" long adjustable solid steel forks
- 12" high fork backs
- Optional motors available
- Optional slip-on 32" x 30" platform
- Custom platforms available
- Leaf-type chain with 8250 lb yield point
- 1500 lb and 2000 lb capacities available
- Standard remote control with coil cord
- Coil cord (4' retracted, 20' extended)

## Hand-Crank Mechanical Stackers

Model Number	Load Capacity	Raised Height	Lowered Height	Dimensions H / W / L	Base Legs I.D. / O.D.	Wheel Dia. Front/Rear	Shipping Weight	Price Each
<b>MV Series - Platform (24" x 24") - 15" Load Center</b>								
MV54	750 lbs	54"	4-1/2"	71 x 24 x 37"	19" / 24"	4" / 6"	380 lbs	\$1,840
MV60	750 lbs	60"	4-1/2"	77 x 24 x 37"	19" / 24"	4" / 6"	420 lbs	\$1,980
MV78	750 lbs	76"	4-1/2"	95 x 24 x 37"	19" / 24"	4" / 6"	460 lbs	\$2,130
<b>MVF Series - Adjustable Forks (30" Long) - 15" Load Center</b>								
MVF56	750 lbs	56"	1"	77 x 31-1/2 x 41"	26" / 31"	4" / 6"	460 lbs	\$2,260
MVF74	750 lbs	74"	1"	95 x 31-1/2 x 41"	26" / 31"	4" / 6"	500 lbs	\$2,400

Units over 93" in height will be shipped in the horizontal position.



### Features

- 750 lb capacity
- 15" load centers
- Heavy-duty floor lock
- Floor-saving phenolic wheels
- Adjustable 30" long forks
- Safety ratchet and pawl hold load at desired height
- Hoist mechanism features a spur-gear winding drum, friction-type clutch / brake assembly and 1/4" plow steel wire rope

Stacker options on page 11

# Stacker Options

Description and Specification	List Price
<b>Reversed (Inverted) Forks:</b> Ideal for overhead installation. Forks can be modified in a reverse position, giving an increased lowered/raised height.	\$190
<b>R-5 Roller Bed:</b> Excellent for transferring heavy objects to and from a lift with minimum effort. Front or side loading. Rollers are on a 3" center. 27 x 30" area mounted on a 32 x 36" slip-on platform. 1000 lb capacity, weight is 145 lbs. Requires a 24" load center.	Call for Pricing
<b>P-6 Die Puller:</b> Equipped with a hand operated winch with cable and hook for pulling dies over a roller bed. 27 x 30" roller area mounted on a 32 x 30" slip-on platform. 1000 lb capacity, weight is 185 lbs. Requires 24" load center.	Call for Pricing
<b>AC Power Unit (in place of standard DC power unit)</b> 115V/1PH AC motor with hydraulic pump with RC-10 hand controls	\$420
<b>AC Power Unit (in place of standard DC power unit)</b> 115V/1PH AC motor with hydraulic pump with RC-20 hand controls	\$520
<b>Air Power (in place of standard DC power unit)</b> Air motor with hydraulic pump. 1.5 GPM at 80 PSI and 80 CFM of free air with lift fully loaded. Includes a hand or foot control valve (FRL not included.) <b>Air Filter &amp; lubricator</b>	\$980 \$400
<b>Remote Control:</b> Hand or foot operated controls w/ coil cord. Factory installed. RC-10 RC-20 FC-10	\$390 \$490 \$490
<b>Fire Resistant Hydraulic Fluid:</b> Water glycol fluids are fire resistant, non-explosive and non-toxic. Approved by Factory Mutual Insurance Engineering Laboratories.	\$255
<b>Battery Status Meter</b>	\$160
<b>Shortened Forks</b>	\$100
<b>Forks Flat to Floor</b>	\$90
<b>DG-30 Drum Grabber</b>	\$2095

## Ram In place of standard forks

Model Number	Description and Specification	Shipping Weight	Price Each
Interchanges with forks on adjustable fork models with sheet metal back plates, for roll and coil handling.			
RR1	Ram 2-1/2" round x 20" L, 1000 lb cap @ 15" LC	13 lbs	\$250
RR2	Ram 2-1/2" round x 24" L, 1000 lb cap @ 18" LC	16 lbs	\$280
RR3	Ram 2-1/2" round x 13" L, 1000 lb cap @ 13" LC	12 lbs	\$240
RR4	Ram 2-1/2" round x 30" L, 1000 lb cap @ 15" LC	20 lbs	\$310
RS1	Ram 3" square x 20" L, 1500 lb cap @ 20" LC	15 lbs	\$260
RS2	Ram 3" square x 24" L, 1500 lb cap @ 18" LC	24 lbs	\$300
RS3	Ram 2-1/2" square x 30" L, 1500 lb cap @ 20" LC	22 lbs	\$320
RS4	Ram 3" square x 30" long, 1500 lb capacity @ 20" LC	27 lbs	\$330
Interchanges with fork models with shaft (ps) back plate.			
RSPS24	Ram 3" square x 24" L, 1500 lb cap @ 18" LC	35 lbs	\$370
RSPS30	Ram 3" square x 30" L, 1500 lb cap @ 20" LC	35 lbs	\$390
RSPS36	Ram 3" square x 36" L, 1500 lb cap @ 24" LC	35 lbs	\$410

## Boom with Hook In place of standard forks

Model Number	Description and Specification	Shipping Weight	Price Each
Mounts on fork model with sheet metal back plates for lifting and suspending loads.			
BP13	13" boom with hook, 1000 lb cap @ 13" LC	22 lbs	\$320
BP15	15" boom with hook, 1000 lb cap @ 15" LC	22 lbs	\$330
BP18	18" boom with hook, 1000 lb cap @ 18" LC	24 lbs	\$350
BP20	20" boom with hook, 1000 lb cap @ 20" LC	25 lbs	\$360
Mounts on fork models with shaft (ps) back plate.			
B20-15PS	20" boom with hook, 1000 lb cap @ 20" LC	35 lbs	\$390
B24-15PS	24" boom with hook, 1000 lb cap @ 24" LC	45 lbs	\$440

## Slip-on Platform

Model Number	Description and Specification	Shipping Weight	Price Each
SP24	Slip-on platform, 24" x 24" for 13" and 15" LC	32 lbs	\$280
SP32	Slip-on platform, 32" x 30" for 18" and 20" LC	52 lbs	\$320
SP40	Slip-on platform, 40" x 36" for 24" LC	95 lbs	\$430
Custom platform sizes available, please contact Sales.			

# Pallet Positioner

## P3™ - Presto Pallet Positioner Load Leveler/Rotator

Model Number	Load Capacity	Raised Height	Lowered Height	Overall Base W / L	Turntable Diameter	Shipping Weight	Price Each
<b>Pallet Positioner</b>							
P3	4500 lbs	30-1/2"	9-1/2"	36 x 48"	43-5/8"	615 lbs	\$2,305

### Load and unload pallets without stooping, stretching, or walking

The P3 Presto Pallet Positioner automatically maintains pallets at a constant level and comfortable working height as layers of boxes are added or removed. Leveling is accomplished by a heavy-duty, reinforced rubber airbag that, once charged with shop air, can handle loads up to 4500 lbs. After airbag charging is complete, the P3 can be disconnected and moved to any location in the plant. Because the P3 is pneumatic, it can accommodate loads that vary substantially in weight (from 400 - 4500 lbs) so one unit is versatile enough to work in several areas.

The P3 - Presto Pallet Positioner features a turntable top with full 360° rotation. Anti-friction bearings for easy turning allow users to spin loads so they are always loading and unloading from the near side without having to walk around the unit.

*Complete the system with a Presto Stacker for easy feeding and off-loading of the P3.*

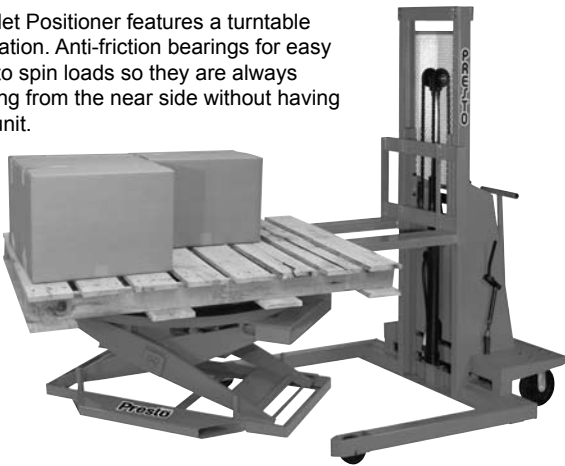

### Available P3 Options:

Plastic Cover: Keeps debris from falling through turntable.....	\$105
Rotator Ring Disc Cover.....	\$150
Solid Turntable Top: Accommodates small or odd-size pallets; Rectangular or Square Cover.....	\$425
Ring Lock.....	\$145
Bellows Guard: Prevents debris from collecting under unit.....	\$750

Presto P3's improve productivity and worker comfort in a wide variety of applications, including:

#### Printing & Publishing

#### Graphic Arts

#### Metalworking

#### Woodworking

#### Machine Feeding or Off-loading

Anywhere that pallet loads are built or broken down!

## Accuload Positioner

Model Number	Load Capacity	Raised Height	Lowered Height	Overall Base W / L	Turntable Diameter	Shipping Weight	Price Each
<b>Accuload Series</b>							
AL30	3000 lbs	30-1/4"	9-7/8"	24 x 48"	43"	500 lbs	\$2,910

### Features

- 3000 lb holding capacity
- 1500 lb lifting capacity
- 21" vertical travel
- Foot control standard
- Optional pedestal control available
- Pressure relief valve standard
- 3/8" x 43" solid rotating platform
- Lifetime warranty on actuator
- Air requirements: 80 psi at 15 cfm
- Custom platforms available

Pneumatic options on page 30



Highlighted models are AIS (Always In Stock) and ship within one week.

## Standard-Duty Scissor Lifts

Model Number	Load Capacity	Raised Height	Lowered Height	End/Side Capacity	Std. Base & Platform	Maximum Platform	Lifting Speed	Standard Motor	Std. Voltage/Phase/Hz	Shipping Weight	Price Each
<b>XL24 Series - 24" Travel</b>											
XL24-20	2000 lbs	31"	7-1/4"	2000 lbs	24 x 36"	48 x 60"	15 sec	1 HP	115/1/60	550 lbs	\$3,350
XL24-40	4000 lbs	31"	7-1/4"	4000 lbs	24 x 36"	48 x 60"	27 sec	1 HP	115/1/60	570 lbs	\$3,760
XL24-60	6000 lbs	31"	7-1/4"	4500 lbs	24 x 36"	48 x 60"	40 sec	1 HP	115/1/60	620 lbs	\$4,190
<b>XL36 Series - 36" Travel</b>											
XL36-20	2000 lbs	43"	7-1/4"	2000 lbs	24 x 48"	48 x 72"	17 sec	1 HP	115/1/60	690 lbs	\$2,740
XL36-30	3000 lbs	43"	7-1/4"	3000 lbs	24 x 48"	48 x 72"	30 sec	1 HP	115/1/60	720 lbs	\$2,960
XL36-40	4000 lbs	43"	7-1/4"	3500 lbs	24 x 48"	48 x 72"	38 sec	1 HP	115/1/60	750 lbs	\$3,500
XL36-50	5000 lbs	43"	7-1/4"	3500 lbs	24 x 48"	48 x 72"	22 sec	1-1/2 HP	230, 460/3/60	770 lbs	\$3,900
XL36-60	6000 lbs	43"	7-1/4"	3500 lbs	24 x 48"	48 x 72"	30 sec	1-1/2 HP	230, 460/3/60	790 lbs	\$4,170
XL36-80	8000 lbs	45"	9"	4000 lbs	30 x 60"	54 x 84"	21 sec	3 HP	230, 460/3/60	1350 lbs	\$8,620
<b>XL48 Series - 48" Travel</b>											
XL48-20	2000 lbs	55"	7-1/4"	2000 lbs	24 x 64"	48 x 88"	19 sec	1-1/2 HP	230, 460/3/60	850 lbs	\$3,760
XL48-40	4000 lbs	55"	7-1/4"	3500 lbs	24 x 64"	48 x 88"	32 sec	1-1/2 HP	230, 460/3/60	900 lbs	\$4,170
XL48-60	6000 lbs	55"	7-1/4"	3500 lbs	24 x 64"	48 x 88"	39 sec	1-1/2 HP	230, 460/3/60	950 lbs	\$4,600
XL48-80	8000 lbs	57"	9"	4000 lbs	24 x 66"	48 x 96"	30 sec	3 HP	230, 460/3/60	1350 lbs	\$9,390
<b>XL60 Series - 60" Travel</b>											
XL60-20	2000 lbs	70"	10"	1000 lbs	24 x 86"	48 x 120"	10 sec	3 HP	230, 460/3/60	1300 lbs	\$5,780
XL60-40	4000 lbs	70"	10"	2000 lbs	24 x 86"	48 x 120"	20 sec	3 HP	230, 460/3/60	1375 lbs	\$7,580
XL60-60	6000 lbs	70"	10"	3000 lbs	24 x 86"	48 x 120"	30 sec	3 HP	230, 460/3/60	1450 lbs	\$9,010
XL60-80	8000 lbs	70"	10"	4000 lbs	24 x 86"	48 x 120"	42 sec	3 HP	230, 460/3/60	1700 lbs	\$11,100

Please specify voltage and control type when ordering.

### Features

- Standard hand control pendant
- Optional foot control available
- Easy-to-access internal power unit
- Optional power units available
- Heavy-duty hydraulic cylinders with chrome-plated rams
- Polyurethane seals on cylinders
- 3-1/2" table edge to protect operator from rollers
- 3/4" steel plate scissor legs
- Lifetime lubricated bearings on all rollers and pivot points
- Maintenance device
- Custom designs available
- Oversized platforms available



Scissor lift options on page 25

Highlighted models are AIS (Always In Stock) and ship within one week.

# Wide-Base Scissor Lifts

## Wide-Base Scissor Lifts

Model Number	Load Capacity	Raised Height	Lowered Height	End/Side Capacity	Std. Base & Platform	Maximum Platform	Lifting Speed	Standard Motor	Std. Voltage/Phase/Hz	Shipping Weight	Price Each
<b>X3W Series - 24" Travel</b>											
X3W24-20	2000 lbs	31"	7-3/4"	2000 lbs	36 x 36"	60 x 60"	30 sec	1 HP	115/1/60	720 lbs	\$4,140
X3W24-40	4000 lbs	31"	7-3/4"	4000 lbs	36 x 36"	60 x 60"	32 sec	1 HP	115/1/60	740 lbs	\$4,490
X3W24-60	6000 lbs	31"	7-3/4"	4500 lbs	36 x 36"	60 x 60"	34 sec	1 HP	115/1/60	790 lbs	\$4,890
<b>X3W Series - 36" Travel</b>											
X3W36-20	2000 lbs	43"	7-3/4"	2000 lbs	36 x 48"	60 x 72"	44 sec	1 HP	115/1/60	860 lbs	\$4,020
X3W36-40	4000 lbs	43"	7-3/4"	3500 lbs	36 x 48"	60 x 72"	46 sec	1 HP	115/1/60	900 lbs	\$4,390
X3W36-60	6000 lbs	43"	7-3/4"	3500 lbs	36 x 48"	60 x 72"	26 sec	1-1/2 HP	230, 460/3/60	960 lbs	\$4,930
<b>X3W Series - 48" Travel</b>											
X3W48-20	2000 lbs	55"	7-3/4"	2000 lbs	36 x 64"	60 x 88"	32 sec	1-1/2 HP	230, 460/3/60	1020 lbs	\$4,500
X3W48-40	4000 lbs	55"	7-3/4"	3500 lbs	36 x 64"	60 x 88"	34 sec	1-1/2 HP	230, 460/3/60	1070 lbs	\$4,940
X3W48-60	6000 lbs	55"	7-3/4"	3500 lbs	36 x 64"	60 x 88"	38 sec	1-1/2 HP	230, 460/3/60	1120 lbs	\$5,520
<b>X4W Series - 24" Travel</b>											
X4W24-20	2000 lbs	31"	7-3/4"	2000 lbs	48 x 36"	72 x 60"	30 sec	1 HP	115/1/60	810 lbs	\$4,370
X4W24-40	4000 lbs	31"	7-3/4"	4000 lbs	48 x 36"	72 x 60"	32 sec	1 HP	115/1/60	830 lbs	\$4,770
X4W24-60	6000 lbs	31"	7-3/4"	4500 lbs	48 x 36"	72 x 60"	34 sec	1 HP	115/1/60	880 lbs	\$5,250
<b>X4W Series - 36" Travel</b>											
X4W36-20	2000 lbs	43"	7-3/4"	2000 lbs	48 x 48"	72 x 72"	44 sec	1 HP	115/1/60	950 lbs	\$4,370
X4W36-40	4000 lbs	43"	7-3/4"	3500 lbs	48 x 48"	72 x 72"	46 sec	1 HP	115/1/60	990 lbs	\$4,650
X4W36-60	6000 lbs	43"	7-3/4"	3500 lbs	48 x 48"	72 x 72"	26 sec	1-1/2 HP	230, 460/3/60	1050 lbs	\$5,250
<b>X4W Series - 48" Travel</b>											
X4W48-20	2000 lbs	55"	7-3/4"	2000 lbs	48 x 64"	72 x 88"	32 sec	1-1/2 HP	230, 460/3/60	1110 lbs	\$4,770
X4W48-40	4000 lbs	55"	7-3/4"	3500 lbs	48 x 64"	72 x 88"	30 sec	1-1/2 HP	230, 460/3/60	1160 lbs	\$5,250
X4W48-60	6000 lbs	55"	7-3/4"	3500 lbs	48 x 64"	72 x 88"	38 sec	1-1/2 HP	230, 460/3/60	1250 lbs	\$5,650
X4W48-80	8000 lbs	57"	9"	4000 lbs	48 x 66"	72 x 88"	30 sec	3 HP	230, 460/3/60	1550 lbs	\$10,530
<b>X4.5W Series - 60" Travel</b>											
X4.5W60-20	2000 lbs	70"	10"	1000 lbs	54 x 86"	84 x 120"	10 sec	3 HP	230, 460/3/60	1650 lbs	\$7,060
X4.5W60-40	4000 lbs	70"	10"	2000 lbs	54 x 86"	84 x 120"	20 sec	3 HP	230, 460/3/60	1725 lbs	\$8,650
X4.5W60-60	6000 lbs	70"	10"	3000 lbs	54 x 86"	84 x 120"	30 sec	3 HP	230, 460/3/60	1800 lbs	\$10,040
X4.5W60-80	8000 lbs	70"	10"	4000 lbs	54 x 86"	84 x 120"	42 sec	3 HP	230, 460/3/60	2150 lbs	\$12,370

Please specify voltage and control type when ordering.

## Features



- Standard hand control pendant
- Optional foot control available
- Easy-to-access internal power unit
- Optional power units available
- Heavy-duty hydraulic cylinders with chrome-plated rams
- Polyurethane seals on cylinders
- 3-1/2" table edge to protect operator from rollers
- 3/4" steel plate scissor legs
- Lifetime lubricated bearings on all rollers and pivot points
- Maintenance device
- Custom designs available
- Oversized platforms available

Scissor lift options on page 25

# Tandem and Dual Scissor Lifts

## Tandem Scissor Lifts

Model Number	Load Capacity	Raised Height	Lowered Height	Std. Base & Platform	Maximum Platform	Lifting Speed	Standard Motor	Std. Voltage/Phase/Hz	Shipping Weight	Price Each
<b>XL36T Series - 36" Travel</b>										
XL36T-40	4000 lbs	43"	7-1/4"	24 x 96"	48 x 120"	34 sec	1 HP	115/1/60	1280 lbs	\$6,480
XL36T-80	8000 lbs	43"	7-1/4"	24 x 96"	48 x 120"	44 sec	1-1/2 HP	230, 460/3/60	1340 lbs	\$7,980
XL36T-120	12000 lbs	43"	7-1/4"	24 x 96"	48 x 120"	60 sec	1-1/2 HP	230, 460/3/60	1400 lbs	\$9,490
<b>XL48T Series - 48" Travel</b>										
XL48T-40	4000 lbs	55"	7-1/4"	24 x 128"	48 x 168"	28 sec	1-1/2 HP	230, 460/3/60	1600 lbs	\$8,690
XL48T-80	8000 lbs	55"	7-1/4"	24 x 128"	48 x 168"	64 sec	1-1/2 HP	230, 460/3/60	1700 lbs	\$9,490
XL48T-120	12000 lbs	55"	7-1/4"	24 x 128"	48 x 168"	78 sec	1-1/2 HP	230, 460/3/60	1800 lbs	\$10,590
<b>XL60T Series - 60" Travel</b>										
XL60T-40	4000 lbs	70"	10"	24 x 172"	48 x 204"	20 sec	3 HP	230, 460/3/60	2500 lbs	\$11,960
XL60T-80	8000 lbs	70"	10"	24 x 172"	48 x 204"	40 sec	3 HP	230, 460/3/60	2650 lbs	\$14,880
XL60T-120	12000 lbs	70"	10"	24 x 172"	48 x 204"	60 sec	3 HP	230, 460/3/60	2750 lbs	\$17,860

### Features

- Upper travel limit switch and Lifting eyes included on all Tandem and Dual Scissor Lifts
- For platform sizes and capacities not shown above, please contact sales
- Application information must be reviewed for all Tandem Lifts. Approval drawings will be provided.

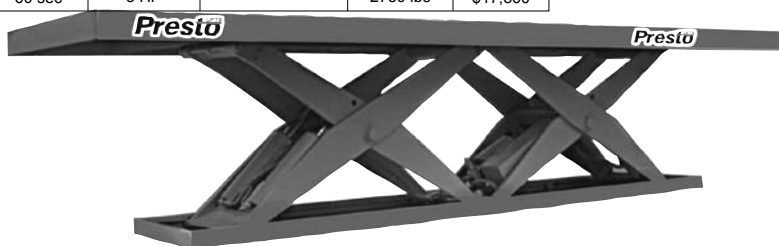

## Wide Base Tandem Scissor Lifts

Model Number	Load Capacity	Raised Height	Lowered Height	Std. Base & Platform	Maximum Platform	Lifting Speed	Standard Motor	Std. Voltage/Phase/Hz	Shipping Weight	Price Each
<b>X3W36T Series - 36" Travel</b>										
X3W36T-40	4000 lbs	43"	7-3/4"	36 x 96"	60 x 120"	48 sec	1-1/2 HP	230, 460/3/60	1620 lbs	\$8,990
X3W36T-80	8000 lbs	43"	7-3/4"	36 x 96"	60 x 120"	50 sec	1-1/2 HP	230, 460/3/60	1700 lbs	\$9,780
X3W36T-120	12000 lbs	43"	7-3/4"	36 x 96"	60 x 120"	52 sec	1-1/2 HP	230, 460/3/60	1820 lbs	\$10,980
<b>X4W48T Series - 48" Travel</b>										
X4W48T-40	4000 lbs	55"	7-3/4"	48 x 128"	72 x 168"	64 sec	1-1/2 HP	230, 460/3/60	2120 lbs	\$10,740
X4W48T-80	8000 lbs	55"	7-3/4"	48 x 128"	72 x 168"	68 sec	1-1/2 HP	230, 460/3/60	2220 lbs	\$11,700
X4W48T-120	12000 lbs	55"	7-3/4"	48 x 128"	72 x 168"	76 sec	1-1/2 HP	230, 460/3/60	2400 lbs	\$12,680
<b>X4.5W60T Series - 60" Travel</b>										
X4.5W60T-40	4000 lbs	70"	10"	54 x 172"	84 x 204"	20 sec	3 HP	230, 460/3/60	3200 lbs	\$14,460
X4.5W60T-80	8000 lbs	70"	10"	54 x 172"	84 x 204"	40 sec	3 HP	230, 460/3/60	3350 lbs	\$17,300
X4.5W60T-120	12000 lbs	70"	10"	54 x 172"	84 x 204"	60 sec	3 HP	230, 460/3/60	3500 lbs	\$19,860

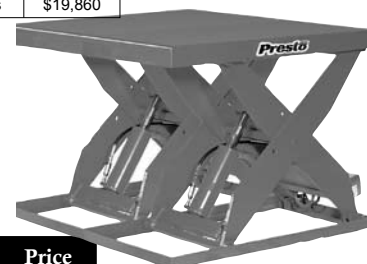

## Dual Scissor Lifts

Model Number	Load Capacity	Raised Height	Lowered Height	Std. Base & Platform	Maximum Platform	Lifting Speed	Standard Motor	Std. Voltage/Phase/Hz	Shipping Weight	Price Each
<b>XL36D Series - 36" Travel</b>										
XL36D-40	4000 lbs	43"	7-1/4"	48 x 48"	72 x 72"	34 sec	1 HP	115/1/60	1280 lbs	\$6,480
XL36D-80	8000 lbs	43"	7-1/4"	48 x 48"	72 x 72"	44 sec	1-1/2 HP	230, 460/3/60	1340 lbs	\$7,980
XL36D-120	12000 lbs	43"	7-1/4"	48 x 48"	72 x 72"	60 sec	1-1/2 HP	230, 460/3/60	1400 lbs	\$9,490
<b>XL48D Series - 48" Travel</b>										
XL48D-40	4000 lbs	55"	7-1/4"	48 x 64"	72 x 96"	64 sec	1-1/2 HP	230, 460/3/60	1600 lbs	\$8,690
XL48D-80	8000 lbs	55"	7-1/4"	48 x 64"	72 x 96"	72 sec	1-1/2 HP	230, 460/3/60	1700 lbs	\$9,490
XL48D-120	12000 lbs	55"	7-1/4"	48 x 64"	72 x 96"	78 sec	1-1/2 HP	230, 460/3/60	1800 lbs	\$10,590
<b>XL60D Series - 36" Travel</b>										
XL60D-40	4000 lbs	70"	10"	48 x 86"	72 x 120"	20 sec	3 HP	230, 460/3/60	2500 lbs	\$11,960
XL60D-80	8000 lbs	70"	10"	48 x 86"	72 x 120"	40 sec	3 HP	230, 460/3/60	2650 lbs	\$14,880
XL60D-120	12000 lbs	70"	10"	48 x 86"	72 x 120"	60 sec	3 HP	230, 460/3/60	2750 lbs	\$17,860

Scissor lift options on page 25



# Light-Duty Scissor Lifts

## Light-Duty Manual Scissor Lifts

Model Number	Load Capacity	Raised Height	Lowered Height	End/Side Capacity	Std. Base & Platform	Maximum Platform	Lifting Strokes	Shipping Weight	Price Each
<b>XF24 Series</b>									
XF24-10	1000 lbs	29"	5-1/4"	1000 lbs	24 x 36"	36 x 42"	35	390 lbs	\$1,840
XF24-15	1500 lbs	29"	5-1/4"	1500 lbs	24 x 36"	36 x 42"	55	395 lbs	\$1,930
XF24-20	2000 lbs	31"	7-1/4"	2000 lbs	24 x 36"	48 x 60"	85	500 lbs	\$2,510
<b>XF36 Series</b>									
XF36-10	1000 lbs	41"	5-1/4"	1000 lbs	24 x 48"	36 x 54"	46	440 lbs	\$2,030
XF36-15	1500 lbs	41"	5-1/4"	1500 lbs	24 x 48"	36 x 54"	69	455 lbs	\$2,110
XF36-20	2000 lbs	43"	7-1/4"	2000 lbs	24 x 48"	48 x 72"	130	650 lbs	\$2,610
<b>WXF24 Series</b>									
WXF24-10	1000 lbs	29-1/4"	5-1/4"	1000 lbs	36 x 36"	48 x 42"	35	430 lbs	\$2,210
WXF24-15	1500 lbs	29-1/4"	5-1/4"	1500 lbs	36 x 36"	48 x 42"	55	435 lbs	\$2,290
<b>WXF36 Series</b>									
WXF36-10	1000 lbs	41-1/4"	5-1/4"	1000 lbs	36 x 48"	48 x 54"	46	480 lbs	\$2,320
WXF36-15	1500 lbs	41-1/4"	5-1/4"	1500 lbs	36 x 48"	48 x 54"	69	485 lbs	\$2,400



XF36-10 Shown

### Features

- Foot-operated hydraulic pump provides lift
- Hand-controlled release for lowering
- 1/2" steel plate scissor legs
- 2000 lb capacity models feature 3/4" thick steel scissor legs
- Wide-base models
- Oversized & custom platforms available
- Hinged platform allows easy access to cylinders
- Chrome-plated ram cylinders
- Custom designs available

## Light-Duty Electric Scissor Lifts

Model Number	Load Capacity	Raised Height	Lowered Height	End/Side Capacity	Std. Base & Platform	Maximum Platform	Lifting Speed	Shipping Weight	Price Each
<b>XS24 Series - 24" Travel - 24" W x 36" L Platform</b>									
XS24-10	1000 lbs	29"	5-1/4"	1000 lbs	24 x 36"	36 x 48"	18 sec	390 lbs	\$2,290
XS24-15	1500 lbs	29"	5-1/4"	1500 lbs	24 x 36"	36 x 48"	23 sec	395 lbs	\$2,360
<b>XS36 Series - 36" Travel - 24" W x 48" L Platform</b>									
XS36-10	1000 lbs	41"	5-1/4"	1000 lbs	24 x 48"	36 x 60"	29 sec	425 lbs	\$2,360
XS36-15	1500 lbs	41"	5-1/4"	1500 lbs	24 x 48"	36 x 60"	36 sec	430 lbs	\$2,410
<b>WXS24 Series - 24" Travel - 36" W x 36" L Platform</b>									
WXS24-10	1000 lbs	29-1/4"	5-1/4"	1000 lbs	36 x 36"	48 x 48"	18 sec	430 lbs	\$2,710
WXS24-15	1500 lbs	29-1/4"	5-1/4"	1500 lbs	36 x 36"	48 x 48"	23 sec	435 lbs	\$2,760
<b>WXS36 Series - 36" Travel - 36" W x 48" L Platform</b>									
WXS36-10	1000 lbs	41-1/4"	5-1/4"	1000 lbs	36 x 48"	48 x 60"	29 sec	455 lbs	\$2,750
WXS36-15	1500 lbs	41-1/4"	5-1/4"	1500 lbs	36 x 48"	48 x 60"	36 sec	470 lbs	\$2,810

### Features

- Standard hand-control pendant
- Easy-to-service internal power unit
- 1-2" steel plate scissor legs
- Powered up, powered down units
- Hinged platform allows for easy access to cylinders
- Internal 1/3 HP 115/1/60 power unit
- Custom designs available

Scissor lift options on page 25



XS36-15 Shown

Highlighted models are AIS (Always In Stock) and ship within one week.

# Portable Scissor Lifts

## Portable Manual Scissor Lifts

Model Number	Load Capacity	Raised Height	Lowered Height	Standard Platform	Maximum Platform	Lifting Strokes	Shipping Weight	Price Each
<b>XP24 Series - 23" Travel</b>								
XP24-300	300 lbs	33"	10"	20 x 32"	20 x 32"	12	250 lbs	\$920
XP24-600	600 lbs	33"	10"	20 x 32"	20 x 32"	25	260 lbs	\$1,020
<b>XP24 Series - 24" Travel</b>								
XP24-10	1000 lbs	33"	9-1/4"	24 x 36"	30 x 42"	35	410 lbs	\$1,610
XP24-15	1500 lbs	33"	9-1/4"	24 x 36"	30 x 42"	55	415 lbs	\$1,690
XP24-20	2000 lbs	41-1/2"	17-1/2"	24 x 36"	48 x 48"	85	750 lbs	\$2,980
<b>XP36 Series - 36" Travel</b>								
XP36-10	1000 lbs	45"	9-1/4"	24 x 48"	30 x 54"	46	440 lbs	\$1,790
XP36-15	1500 lbs	45"	9-1/4"	24 x 48"	30 x 54"	69	445 lbs	\$1,870
XP36-20	2000 lbs	53-1/2"	17-1/2"	24 x 48"	48 x 60"	130	900 lbs	\$2,930
<b>WXP24 Series - 24" Travel</b>								
WXP24-10	1000 lbs	33-1/4"	9-1/4"	36 x 36"	42 x 42"	35	450 lbs	\$2,010
WXP24-15	1500 lbs	33-1/4"	9-1/4"	36 x 36"	42 x 42"	55	455 lbs	\$2,100
<b>WXP36 Series - 36" Travel</b>								
WXP36-10	1000 lbs	45-1/4"	9-1/4"	36 x 48"	48 x 54"	46	480 lbs	\$2,150
WXP36-15	1500 lbs	45-1/4"	9-1/4"	36 x 48"	48 x 54"	69	485 lbs	\$2,230



XP24-600



### Features

- Hand-release for lowering
- Foot-operated hydraulic pump
- 1/2" steel plate scissor legs
- 2000 lb capacity models feature 3/4" thick steel scissor legs
- Two fixed & two swivel 5" x 2" high-impact phenolic casters
- Hinged platform allows for access to cylinders
- Foot-operated floor lock
- Oversized and custom platforms available
- Optional casters available
- Custom designs available

## Portable Electric Scissor Lifts

Model Number	Load Capacity	Raised Height	Lowered Height	End/Side Capacity	Std. Base & Platform	Maximum Platform	Lifting Speed	Shipping Weight	Price Each
<b>XS24 Series - 24" Travel - 24" W x 36" L Platform</b>									
XBP24-10	1000 lbs	33"	9-1/4"	1000 lbs	24 x 36"	30 x 42"	10 sec	470 lbs	\$2,510
XBP24-15	1500 lbs	33"	9-1/4"	1500 lbs	24 x 36"	30 x 42"	15 sec	475 lbs	\$2,630
XBP24-20	2000 lbs	41-1/2"	17-1/2"	2000 lbs	24 x 36"	48 x 48"	15 sec	700 lbs	\$4,980
<b>XS36 Series - 36" Travel - 24" W x 48" L Platform</b>									
XBP36-10	1000 lbs	45"	9-1/4"	1000 lbs	24 x 48"	30 x 54"	14 sec	500 lbs	\$2,630
XBP36-15	1500 lbs	45"	9-1/4"	1500 lbs	24 x 48"	30 x 54"	20 sec	505 lbs	\$2,650
XBP36-20	2000 lbs	53-1/2"	17-1/2"	2000 lbs	24 x 48"	48 x 60"	22 sec	700 lbs	\$4,860
<b>WXS24 Series - 24" Travel - 36" W x 36" L Platform</b>									
WBP24-10	1000 lbs	33-1/4"	9-1/4"	1000 lbs	36 x 36"	42 x 42"	8 sec	460 lbs	\$2,820
WBP24-15	1500 lbs	33-1/4"	9-1/4"	1500 lbs	36 x 36"	42 x 42"	15 sec	465 lbs	\$2,970
<b>WXS36 Series - 36" Travel - 36" W x 48" L Platform</b>									
WBP36-10	1000 lbs	45-1/4"	9-1/4"	1000 lbs	36 x 48"	48 x 54"	14 sec	490 lbs	\$2,960
WBP36-15	1500 lbs	45-1/4"	9-1/4"	1500 lbs	36 x 48"	48 x 54"	20 sec	495 lbs	\$2,990



### Features

- Oversized platforms available
- Two fixed & two swivel 5" x 2" high-impact phenolic casters
- Easy-to-service internal power unit
- 1/2" steel plate scissor legs
- 12V AGM cell battery
- Built-in 5 amp battery charger
- Optional power units available
- Hinged platform allows for easy access to cylinders and power unit
- Foot-operated safety floor lock
- Powered up, powered down
- Custom designs available

Scissor lift options on page 25

Highlighted models are AIS (Always In Stock) and ship within one week.

# Double Scissor Lifts

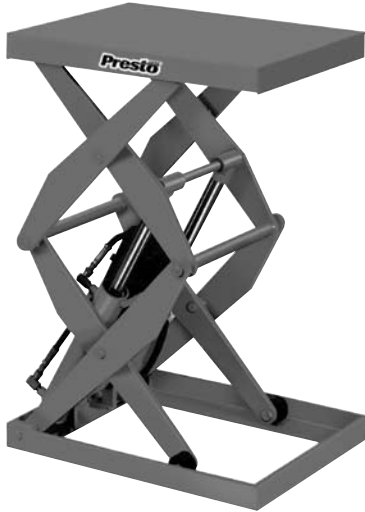

## Compact Scissor Lifts

Model Number	Load Capacity	Raised Height	Lowered Height	Std. Base & Platform	Maximum Platform	Rise Time	Standard Motor	Std. Voltage/Phase/Hz	Shipping Weight	Price Each
<b>DXS30 Series - 30" Travel</b>										
DXS30-5	500 lbs	36-3/4"	6-3/4"	16 x 24"	30 x 36"	16 sec	1/3 HP	115/1/60	350 lbs	\$2,860
DXS30-10	1000 lbs	36-3/4"	6-3/4"	16 x 24"	30 x 36"	18 sec	1/3 HP	115/1/60	350 lbs	\$3,010
<b>DXS36 Series - 36" Travel</b>										
DXS36-10	1000 lbs	43-1/2"	7-1/2"	24 x 36"	36 x 48"	40 sec	1/2 HP	115/1/60	460 lbs	\$3,170
DXS36-15	1500 lbs	43-1/2"	7-1/2"	24 x 36"	36 x 48"	42 sec	1/2 HP	115/1/60	480 lbs	\$3,300
DXS36-20	2000 lbs	44-1/4"	6"	18 x 42" *	36 x 54"	40 sec	1/2 HP	115/1/60	550 lbs	\$3,450
<b>DXS48 Series - 48" Travel</b>										
DXS48-10	1000 lbs	55-1/2"	7-1/2"	24 x 48"	36 x 60"	50 sec	1/2 HP	115/1/60	600 lbs	\$3,490
DXS48-15	1500 lbs	55-1/2"	7-1/2"	24 x 48"	36 x 60"	54 sec	1/2 HP	115/1/60	640 lbs	\$3,640
DXS48-20	2000 lbs	57-1/2"	9-1/2"	24 x 40"	36 x 54"	42 sec	1 HP	115/1/60	800 lbs	\$6,770
DXS48-40	4000 lbs	60"	12"	30 x 42"	48 x 60"	16 sec	3 HP	230, 460/3/60	1250 lbs	\$8,470
<b>DXS60 Series - 60" Travel</b>										
DXS60-20	2000 lbs	76-1/2"	12-1/2"	24 x 53"	42 x 66"	16 sec	3 HP	230, 460/3/60	1100 lbs	\$7,960
DXS60-40	4000 lbs	74"	14"	30 x 53"	48 x 66"	30 sec	3 HP	230, 460/3/60	1800 lbs	\$10,370
<b>DXS72 Series - 72" Travel</b>										
DXS72-20	2000 lbs	84-1/2"	12-1/2"	20 x 53"	36 x 66"	92 sec	1 HP	115/1/60	1250 lbs	\$8,540
DXS72-40	4000 lbs	86"	14"	32 x 57"	54 x 72"	36 sec	3 HP	230, 460/3/60	2000 lbs	\$11,010

### Features

- 500 - 2000 lb capacities
- 30", 36", 48", & 60" vertical travel
- Standard hand pendant control
- Optional power units available
- **DXS36-20 is available with a minimum base/platform size of 18x32" (requires optional remote power unit)**
- DXS30 features power up, power down cylinders
- All other models are power up, gravity down
- Hinged platform allows for easy access to cylinders and power unit in the collapsed position
- Custom designs available
- For higher vertical travel and greater capacity, contact Sales

## Portable Double Scissor Lifts

Model Number	Load Capacity	Raised Height	Lowered Height	Standard Platform	Maximum Platform	Lifting Strokes	Shipping Weight	Price Each
<b>DBP30 Series - 30" Travel - 24" W x 24" L Platform</b>								
DBP30-10	1000 lbs	40-3/4"	10-3/4"	24 x 24"	30 x 30"	8 sec	470 lbs	\$3,930
<b>DBP36 Series - 36" Travel - 24" W x 36" L Platform</b>								
DBP36-10	1000 lbs	47-3/4"	11-3/4"	24 x 36"	30 x 42"	14 sec	505 lbs	\$4,240
DBP36-15	1500 lbs	47-3/4"	11-3/4"	24 x 36"	30 x 42"	20 sec	515 lbs	\$4,390
<b>DBP48 Series - 48" Travel - 24" W x 48" L Platform</b>								
DBP48-10	1000 lbs	59-3/4"	11-3/4"	24 x 48"	30 x 54"	43 sec	650 lbs	\$4,970
DBP48-15	1500 lbs	59-5/8"	11-5/8"	24 x 48"	30 x 54"	43 sec	700 lbs	\$5,120

### Features

- 1000 - 1500 lb capacity
- 30", 36", & 48" vertical travel
- Foot-operated floor lock
- Hinged platform allows for easy access to cylinders and power unit
- Two fixed & two swivel 5" x 2" high-impact phenolic casters
- 12V AGM battery
- Built-in 5 amp battery charger
- DBP36-10/-15, DBP48-10/-15 powered up, gravity down
- Oversized platforms available
- Optional power units available
- Custom designs available



Scissor lift options on page 25

# Post Lift Tables

## Post Lift Tables

Model Number	Load Capacity	Raised Height	Lowered Height	Platform Size	Shipping Weight	Price Each
<b>P18 Series - Foot-operated Tables</b>						
P18-10	1000 lbs	49"	31"	20 x 30"	290 lbs	\$1,050
P18-20	2000 lbs	49"	31"	24 x 36"	300 lbs	\$1,190
P18-30	3000 lbs	49"	31"	24 x 36"	315 lbs	\$1,490
<b>P12 Series - Foot-operated Tables</b>						
P12-10	1000 lbs	37"	25"	20 x 30"	240 lbs	\$1,090
P12-20	2000 lbs	37"	25"	24 x 36"	250 lbs	\$1,320
P12-30	3000 lbs	37"	25"	24 x 36"	260 lbs	\$1,530
<b>BP18 Series - Battery-operated Tables</b>						
BP18-10	1000 lbs	52"	34"	20 x 30"	370 lbs	\$1,720
BP18-20	2000 lbs	52"	34"	24 x 36"	430 lbs	\$1,780
<b>BP12 Series - Battery-operated Tables</b>						
BP12-10	1000 lbs	37"	25"	20 x 30"	270 lbs	\$1,780
BP12-20	2000 lbs	37"	25"	24 x 36"	310 lbs	\$1,930



### Features

- 1000 - 3000 lb capacities
- Foot-operated hydraulic pump on P series
- 12V DC screw drive linear actuator on BP series
- Foot-operated floor lock
- Push-button control on BP series
- Integrated push/pull handle
- 2 fixed and 2 swivel casters with high-impact polyurethane wheels



## Mechanical Post Lift Tables

Model Number	Load Capacity	Raised Height	Lowered Height	Platform Size	Shipping Weight	Price Each
<b>P Series</b>						
P2436	2000 lbs	42"	24"	24 X 36"	400 lbs	\$1,110
P2448	2000 lbs	42"	24"	24 X 48"	460 lbs	\$1,640
P3036	2000 lbs	42"	24"	30 X 36"	445 lbs	\$1,570
P3060	2000 lbs	42"	24"	30 X 60"	600 lbs	\$2,340

### Features

- 2000 lb capacities
- 42" raised height
- Four self-locking acme screw posts
- Two-speed crank shaft for raising & lowering
- Foot-operated floor lock
- 2 fixed and 2 swivel casters with high-impact polyurethane wheels

## Hydraulic Cantilever Tables

Model Number	Load Capacity	Raised Height	Lowered Height	Platform Size	Shipping Weight	Price Each
<b>PL Series</b>						
PL36	2000 lbs	36"	24"	34 x 36"	395 lbs	\$1,270
PL48	2000 lbs	48"	30"	24 x 36"	515 lbs	\$1,460
PL60	2000 lbs	60"	36"	24 x 36"	535 lbs	\$1,530

### Features

- 2000 lb capacities
- Dual floor locks
- Raised heights up to 60"
- Lowered heights down to 24"
- 2 fixed and 2 swivel casters with high-impact phenolic wheels
- Foot-operated hydraulic pump
- Tip-toe release for lowering



Highlighted models are AIS (Always In Stock) and ship within one week.

# Floor Level Access

## Floor Level Lift & Tilt



Model Number	Load Capacity	Raised Height	Lowered Height	Degree of Tilt	Dimensions W x L	Platform Size	Lifting Speed	Shipping Weight	Price Each
<b>XZT44 Series</b>									
XZT44-20	2000 lbs	33-3/8"	3/8"	30°	68 x 61"	44 x 48"	39 sec	1255 lbs	\$8,760
XZT44-40	4000 lbs	33-1/2"	1/2"	30°	68 x 61"	44 x 48"	43 sec	1420 lbs	\$8,990
<b>XZT50 Series</b>									
XZT50-20	2000 lbs	33-3/8"	3/8"	30°	74 x 61"	50 x 48"	40 sec	1420 lbs	\$9,120
XZT50-40	4000 lbs	33-1/2"	1/2"	30°	74 x 61"	50 x 48"	44 sec	1505 lbs	\$9,360

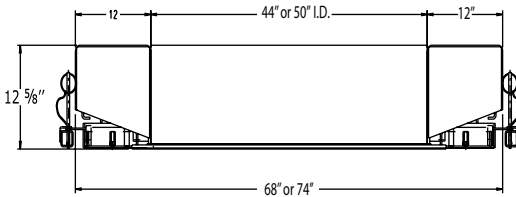

### Features

- 2000 - 4000 lb capacity
- 33" vertical travel
- 30° tilt
- Standard pedestal control
- Optional foot control available
- External 1 HP 115/1/60 power unit
- Optional power units available
- Floor level lowered height
- No ramps or pit required
- Custom designs available
- One power unit controls lift & tilt
- 3-phase available

## Floor Level Container Tilters

Model Number	Tilt Capacity	Lowered Height	Degree of Tilt	Dimensions W x L	Platform Size	Lifting Speed	Shipping Weight	Price Each
<b>ZRT Series</b>								
ZRT50-20	2000 lbs	3/8"	89°	59 x 67"	50 x 48"	26 sec	1245 lbs	\$5,550
ZRT50-40	4000 lbs	3/8"	89°	59 x 67"	50 x 48"	28 sec	1295 lbs	\$5,910

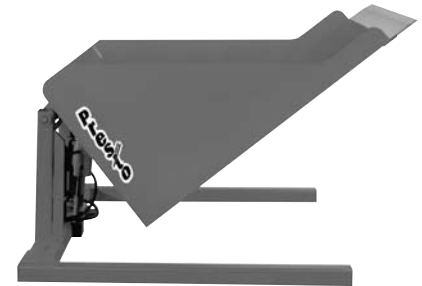

### Features

- 2000 - 4000 lb capacity
- 89° tilt
- Custom platform sizes
- Internal 1 HP 115/1/60 power unit
- Floor level at lowered height
- Pallet jack accessible
- Optional power units available
- 6" flexible safety toe guard
- Hand-control with magnetic back
- Custom designs available
- 50" I.D. x 30-1/8" side height

## Floor Level Tilters

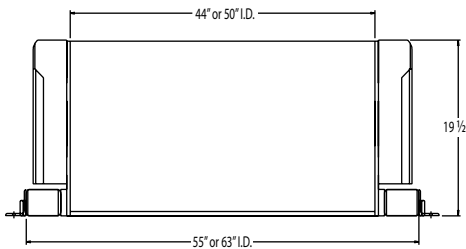

Model Number	Tilt Capacity	Lowered Height	Degree of Tilt	Dimensions W x L	Platform Size	Lifting Speed	Shipping Weight	Price Each
<b>TZ44 Series</b>								
TZ44-20	2000 lbs	3/8"	45°	55 x 60-1/2"	44 x 48"	30 sec	1200 lbs	\$4,690
TZ44-40	4000 lbs	3/8"	45°	55 x 60-1/2"	44 x 48"	32 sec	1155 lbs	\$4,820
TZ44-60	6000 lbs	1/2"	45°	55 x 60-1/2"	44 x 48"	36 sec	1235 lbs	\$6,070
<b>TZ50 Series</b>								
TZ50-20	2000 lbs	3/8"	45°	63 x 60-1/2"	50 x 48"	30 sec	1215 lbs	\$4,820
TZ50-40	4000 lbs	3/8"	45°	63 x 60-1/2"	50 x 48"	34 sec	1240 lbs	\$5,010
TZ50-60	6000 lbs	1/2"	45°	63 x 60-1/2"	50 x 48"	38 sec	1340 lbs	\$6,330



### Features

- 2000 - 4000 lb capacity
- 45° tilt
- Two standard platform sizes
- Floor level at lowered height
- Pallet jack accessible
- External 1 HP 115/1/60 power unit
- Optional power units available
- Hand-control with magnetic back
- 6" flexible safety toe guard
- Custom designs available

Tilt table options on page 25

# Floor-Level Lifts

## Floor-Level Lifts

Model Number	Load Capacity	Raised Height	Lowered Height	Platform Size	Dimensions W / L	Lifting Speed	Shipping Weight	Price Each
<b>XZ44 Series</b>								
XZ44-20	2000 lbs	35-3/8"	3/8"	44 x 48"	61-1/4 x 59"	40 sec	1300 lbs	\$5,310
XZ44-40	4000 lbs	35-3/8"	3/8"	44 x 48"	61-1/4 x 59"	44 sec	1325 lbs	\$5,330
XZ44-60	6000 lbs	35-3/8"	1/2"	44 x 48"	61-1/4 x 59"	54 sec	1750 lbs	\$6,440
<b>XZ50 Series</b>								
XZ50-20	2000 lbs	35-3/8"	3/8"	50 x 48"	67-1/4 x 59"	40 sec	1400 lbs	\$5,430
XZ50-40	4000 lbs	35-3/8"	3/8"	50 x 48"	67-1/4 x 59"	44 sec	1425 lbs	\$5,470
XZ50-60	6000 lbs	35-3/8"	1/2"	50 x 48"	67-1/4 x 59"	54 sec	1850 lbs	\$6,580

### Features

- 2000 - 6000 lb capacities
- 35" vertical travel
- Two standard platform sizes
- External 1 HP 115/1/60 power unit
- Optional power units available
- Foot or hand-held control
- Floor-level at lowered height, pallet truck accessible
- 6" flexible safety toe guard
- Lifting eyes for safe positioning
- Custom designs available



## P4 Floor-Level Loaders

Model Number	Load Capacity	Raised Height	Lowered Height	Platform Size	Dimensions W / L	Lifting Speed	Standard Motor	Std. Voltage/Phase/Hz	Shipping Weight	Price Each
<b>P4 Series</b>										
P4-25-4448	2500 lbs	28"	3/8"	44 x 48"	51 x 61"	22 sec	1 HP	115/1/60	1485 lbs	\$5,460
P4-25-5248	2500 lbs	28"	3/8"	52 x 48"	59 x 61"	22 sec	1 HP	115/1/60	1620 lbs	\$5,970
P4-40-4448	4000 lbs	28"	3/8"	44 x 48"	51 x 61"	30 sec	1 HP	115/1/60	1650 lbs	\$7,900
P4-40-5248	4000 lbs	28"	3/8"	52 x 48"	59 x 61"	30 sec	1 HP	115/1/60	1800 lbs	\$8,530

### Features

- Lowers to floor height so load can be loaded on or off with a hand pallet truck
- Foot switch allows operator to adjust the height of the pallet for loading/unloading at the most convenient working height with minimum reaching or lifting
- Easy and safe pallet loading with narrow side panels to provide operator protection
- Easily moved with a hand pallet jack
- Photoelectric toe guard
- 10 foot control cord pre-wired
- Other voltages available
- Other platform sizes available, please contact Sales.

#### Any of the following controls may be specified at no additional cost:

- NEMA 1, up/down, footswitch with cover and 10 foot control cord
- NEMA 4, up/down, hand-held push-button control with magnet and 10 foot coil cord

#### All standard P4s are shipped with the following:

- Internally mounted power unit
- Reservoir filled with hydraulic oil

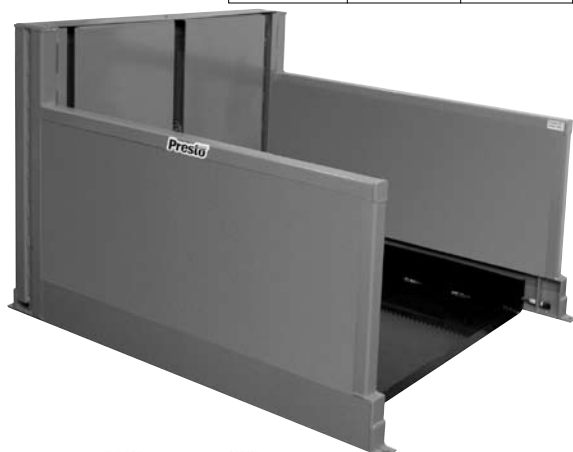

Tilt table options on page 25

# Container Tilters

## Stationary Container Tilters



SRT model shown.

Model Number	Tilt Capacity	Lowered Height	Degree of Tilt	Dimensions W/L	Fork Length	Lifting Speed	Shipping Weight	Price Each
<b>SRT Series</b>								
SRT20	2000 lbs	3/8"	89°	33 x 58"	40"	23 sec	885 lbs	\$3,600
SRT40	4000 lbs	3/8"	89°	33 x 58"	40"	24 sec	900 lbs	\$3,850

### Features

- 2000 - 4000 lb capacity
- 89° tilt
- Internal 1 HP 115/1/60 power unit
- Push-button hand-held control with magnetic backing for mounting
- Optional foot-control available
- Compact frame design
- Designed to be lagged down to the floor
- Fork pockets allow for easy loading with a pallet jack or forklift
- Flexible safety toe guards on forks
- Custom designs available

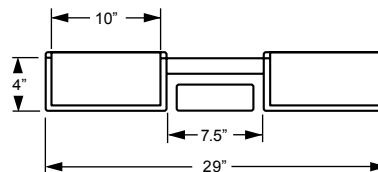

## Portable Container Tilters

Model Number	Tilt Capacity	Lowered Height	Degree of Tilt	Dimensions W/L	Fork Length	Fork O.D.	Lifting Speed	Shipping Weight	Price Each
<b>PT Series - Non-Straddle</b>									
PT-20	2000 lbs	3-1/2"	89°	34 x 62"	42"	26-1/2"	26 sec	825 lbs	\$3,600
PT-40	4000 lbs	3-1/2"	89°	34 x 62"	42"	26-1/2"	30 sec	790 lbs	\$3,700
<b>PTS Series - 42" I.D. Straddle</b>									
PTS42-20	2000 lbs	3-1/2"	89°	48 x 62"	42"	26-1/2"	26 sec	865 lbs	\$3,730
PTS42-40	4000 lbs	3-1/2"	89°	48 x 62"	42"	26-1/2"	30 sec	885 lbs	\$3,850
<b>PTS Series - 50" I.D. Straddle</b>									
PTS50-20	2000 lbs	3-1/2"	89°	56 x 62"	42"	26-1/2"	26 sec	880 lbs	\$3,890
PTS50-40	4000 lbs	3-1/2"	89°	56 x 62"	42"	26-1/2"	30 sec	900 lbs	\$3,970

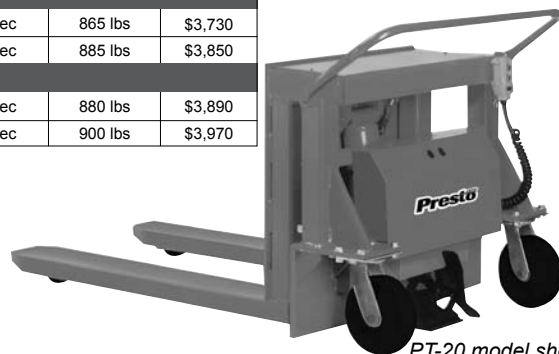

PT-20 model shown.

### Features

- 2000 - 4000 lb capacities
- 89° tilt
- Straddle models for pallets and containers
- Non-straddle models for skids and baskets
- Easy-to-service internal DC motor
- Optional 115V AC or air motors available
- Push-button control with magnetic backing
- External 10 amp battery charger
- Presto foot-operated floor lock
- 12V maintenance free, leak-proof AGM battery
- Push handle lowers when in use
- Custom designs available



PTS50-20 model shown.

Tilt table options on page 25

# Tilt Tables

## Standard Tilt Tables

Model Number	Tilt Capacity	Lowered Height	Degree of Tilt	Standard Base	Standard Platform	Maximum Platform	Lifting Speed	Shipping Weight	Price Each
<b>TT30 Series</b>									
TT30-10	1000 lbs	6-1/2"	30°	24 x 30"	24 x 36"	36 x 48"	15 sec	310 lbs	\$2,720
TT30-15	1500 lbs	6-1/2"	30°	24 x 30"	24 x 36"	36 x 48"	15 sec	325 lbs	\$2,870
TT30-20	2000 lbs	7-1/2"	30°	24 x 36"	24 x 36"	50 x 50"	10 sec	530 lbs	\$3,380
TT30-40	4000 lbs	7-1/2"	30°	24 x 36"	24 x 36"	50 x 50"	11 sec	520 lbs	\$3,790
TT30-60	6000 lbs	7-1/2"	30°	24 x 36"	24 x 36"	50 x 50"	14 sec	530 lbs	\$4,220
<b>TT45 Series</b>									
TT45-10	1000 lbs	6-1/2"	45°	24 x 30"	24 x 36"	36 x 48"	22 sec	310 lbs	\$2,800
TT45-15	1500 lbs	6-1/2"	45°	24 x 30"	24 x 36"	36 x 48"	22 sec	325 lbs	\$2,950
TT45-20	2000 lbs	7-1/2"	45°	24 x 36"	24 x 36"	50 x 50"	15 sec	510 lbs	\$3,490
TT45-40	4000 lbs	7-1/2"	45°	24 x 36"	24 x 36"	50 x 50"	16 sec	520 lbs	\$3,850
TT45-60	6000 lbs	7-1/2"	45°	24 x 36"	24 x 36"	50 x 50"	20 sec	530 lbs	\$4,320
<b>TT60 Series</b>									
TT60-10	1000 lbs	6-1/2"	60°	24 x 30"	24 x 36"	36 x 48"	30 sec	310 lbs	\$2,870
TT60-15	1500 lbs	6-1/2"	60°	24 x 30"	24 x 36"	36 x 48"	50 sec	325 lbs	\$3,030



Shown with optional 12" floor stand



## Wide-Base Tilt Tables

Model Number	Tilt Capacity	Lowered Height	Degree of Tilt	Standard Base	Standard Platform	Maximum Platform	Lifting Speed	Shipping Weight	Price Each
<b>WT30/40 Series</b>									
WT30/45-20	2000 lbs	7-1/2"	30°/45°	36 x 42"	36 x 42"	60 x 60"	19/29 sec	590 lbs	\$4,320
WT30/45-40	4000 lbs	7-1/2"	30°/45°	36 x 42"	36 x 42"	60 x 60"	20/30 sec	610 lbs	\$4,490
WT30/45-60	6000 lbs	7-1/2"	30°/45°	36 x 42"	36 x 42"	60 x 60"	29/39 sec	630 lbs	\$5,070
<b>WT60 Series</b>									
WT60-20	2000 lbs	8-1/2"	60°	36 x 42"	36 x 42"	60 x 60"	40 sec	730 lbs	\$5,760
WT60-40	4000 lbs	8-1/2"	60°	36 x 42"	36 x 42"	60 x 60"	42 sec	750 lbs	\$5,870
WT60-60	6000 lbs	8-1/2"	60°	36 x 42"	36 x 42"	60 x 60"	55 sec	770 lbs	\$6,370
<b>WT90 Series</b>									
WT90-20	2000 lbs	8-1/2"	90°	36 x 42"	36 x 42"	60 x 60"	60 sec	730 lbs	\$5,900
WT90-40	4000 lbs	8-1/2"	90°	36 x 42"	36 x 42"	60 x 60"	64 sec	750 lbs	\$6,030
WT90-60	6000 lbs	8-1/2"	90°	36 x 42"	36 x 42"	60 x 60"	83 sec	770 lbs	\$6,660

### Features

- 1000 - 6000 lb capacities standard
- 2000 - 6000 lb capacities for Wide-Base models
- 30°, 45°, 60°, and 90° tilt
- Standard models have an internal 1/2 HP 115/1/60 power unit
- Wide-Base models have an internal 1 HP 115/1/60 power unit
- Optional power units available
- Powered down cylinders on TT60, WT60, and WT90 series
- Custom platforms available
- 8" standard lip, optional lips up to 24"
- 12" lip standard on WT60 and WT90 series
- All tilt tables can be mounted to the floor, on floor stands, or on top of scissor lifts. Please contact Sales.
- Hand-held control standard
- Optional foot-control available
- Custom designs available. For greater capacity or a larger platform size, contact Sales

Tilt table options on page 25



# Lift & Tilt Tables

## Scissor Lift & Tilt

Model Number	Load Capacity	Raised Height	Lowered Height	Degree of Tilt	Standard Base	Maximum Platform	Lifting Speed	Tilting Speed	Shipping Weight	Price Each
<b>X3WT Series</b>										
X3WT36-20	2000 lbs	47-1/2"	11-1/2"	30°/45°	36 x 48"	60 x 60"	42 sec	8 sec	1370 lbs	\$7,640
X3WT36-40	4000 lbs	47-1/2"	11-1/2"	30°/45°	36 x 48"	60 x 60"	43 sec	8 sec	1420 lbs	\$8,090
<b>X4WT Series</b>										
X4WT36-20	2000 lbs	47-1/2"	11-1/2"	30°/45°	48 x 48"	72 x 60"	42 sec	8 sec	1450 lbs	\$8,090
X4WT36-40	4000 lbs	47-1/2"	11-1/2"	30°/45°	48 x 48"	72 x 60"	43 sec	8 sec	1500 lbs	\$8,450
<b>XLT Series</b>										
XLT36-10	1000 lbs	49-3/4"	13-3/4"	30°/45°	24 x 48"	48 x 48"	20 sec	15 sec	1000 lbs	\$5,610
XLT36-20	2000 lbs	50-3/4"	14-3/4"	30°/45°	24 x 48"	50 x 50"	30 sec	15 sec	1100 lbs	\$6,340
XLT36-40	4000 lbs	50-3/4"	14-3/4"	30°/45°	24 x 48"	50 x 50"	44 sec	15 sec	1350 lbs	\$7,300



Model X3WT shown with standard pedestal control

### X3WT and X4WT standard features:

- Independent lift & tilt functions
- 11-1/2" lowered height
- One power unit for both lift & tilt functions
- Internal 1 HP 115/1/60 power unit
- Standard pedestal controls
- Optional dual foot or dual hand controls available
- Above models feature 30° & 45° tilt (please specify when ordering)

### XLT Series standard features:

- Independent lift & tilt functions
- Lift Power: Internal 1 HP 115/1/60 power unit
- Tilt Power: Internal 1 HP 115/1/60 power unit (1000 lb capacity model features 1/3 HP)
- Standard dual hand or dual foot controls (please specify when ordering)
- Optional pedestal controls available
- Standard 30° or 45° of tilt (please specify when ordering)
- For 60° and 90° tilt models and for higher capacities, contact Sales.

Lift & Tilt tables are a great product to prevent excessive bending and reaching into containers. For Lift & Tilt applications, however, it is always important to know the size of the load, including height, to help determine the load center of gravity as it moves through the tilt application. Please contact your sales coordinator when considering a Lift & Tilt unit for your customer's application.

# Hydraulic Lift Options

## Mechanical Options

## Electrical & Hydraulic Options

Description and Specification	List Price
<b>Oversized Platform</b> - platforms can be increased in width and length up to an additional 24". Side- and end-load capacities are de-rated 2% per inch of increase. Oversized models must be lagged to the floor. <i>Tandem and Dual Series Lift Tables</i>	\$360 \$800
<b>Turntables</b> - See Page 26 <i>Available free-standing, mounted to a stand, or installed on a scissor lift.</i>	Call for Pricing
<b>Gravity Conveyor Top</b> - for straight-line movement of work loads. Available with 1-9/10" and 2-1/2" diameter steel rollers. Specify roller centers. This option adds either 3-3/4" or 4-3/8" to the lowered and raised elevations.	Call for Pricing
<b>Ball Transfer Top</b> - for multi-directional movement of work loads. Available with 1" diameter steel ball casters. Specify ball centers. This option adds either 2-3/4" or 3-3/4" to the lowered and raised elevations.	Call for Pricing
<b>Fixed End &amp; Side Rails</b> - mounted to lift platform or conveyor section. Specify rail height.	Call for Pricing
<b>Optional Platforms &amp; Overlay Material</b> - for special handling of loads. V-cradle tops, stainless steel, diamond plate, and UHMW.	Call for Pricing
<b>Pit-Mounted Units</b> - for ground-level applications, requires either a platform with beveled edges or electro-mechanical toe guard. Lifting eyes required for installation and external motor recommended.	Call for Pricing
<b>Platform with Beveled Edges</b> - welded at 30° angles, increases the standard platform by 4" on all sides.	Call for Pricing
<b>Electro-mechanical Toe Guard and Toe Sensor Edge</b> - mounted to the underside of the platform, adds 4" on all sides.	Call for Pricing
<b>Lifting Eyes</b> - provided for installation and transporting of a unit with a sling or a lifting chain.	\$130
<b>Accordion (Bellows) Skirt</b> - designed to cover the scissor leg assembly of the lift table. <i>XL24 Series</i> <i>XL36 Series</i> <i>XL48 series</i> <i>XL60 Series</i> <i>Additional models and portable lifts, contact Sales</i>	\$450 \$585 \$780 \$1130
<b>Portable / Semi Live Arrangement</b> - Includes two fixed 5" wheels on one side/end (specify side or end mount) and a pull plate with a wheeled dolly handle on the opposite end/side of the base frame. For moving lifts when empty. <i>XL models</i> <i>X3W and X4W models</i> <i>Oversized Platform &amp; other models</i>	\$410 \$470 Call for Pricing
<b>Transportable Units</b> - Two rigid and two swivel casters with 6" dia. steel or texite wheels (please specify) and one Presto heavy duty foot operated floor lock. This option adds between 5" and 10-1/4" to the lowered and raised elevation (elevations vary with caster location; consult Sales if the lowered height is critical). <i>models XL24-20, 40, XL36-20, 40</i> <i>models XL48-20, 40, X3W24-20, 40, X3W36-20, 40, X3W48-20, 40</i> <i>models XL60-20, 40, X4W24-20, 40, X4W36-20, 40, X4W48-20, 40</i> <i>models X4.5W-20, 40</i> <i>Capacities above 4000 lbs, models with oversized platforms, and Lift &amp; Tilt models</i>	\$680 \$760 \$860 \$980 Call for Pricing
<b>Flanged or V-Grooved Wheels</b> - 5" steel wheels for Transportable Units only, sold per pair.	Call for Pricing
<b>Removable Push Handle</b>	\$150
<b>Fork Pockets</b> - 6" x 3" or 8" x 3" enclosed steel tube. Specify fork spread when consulting sales. Adds 3" to the lowered and raised elevations when mounted under the base frame.	Call for Pricing
<b>Super Cycle</b> For high-cycle applications, contact Sales. Components in the base frames have been designed for high-volume, repetitive lifting applications.	Call for Pricing

Description and Specification	List Price
NEMA 1 foot control with Safety Cover and 10' cord (in place of standard hand control)	\$90
NEMA 1 wall mount push button, no cord (in place of standard hand control)	\$110
NEMA 4 Hand controls and NEMA 4 foot controls	Call for Pricing
<b>Pedestal-mounted Controls</b> - NEMA 12 controller mounted on a rugged steel stand with momentary push buttons.	Call for Pricing
<b>Optional Control Voltage</b> - standard control voltage is 115V/1/60, can be upgraded to 24V/1/60 or 24V DC.	Call for Pricing
<b>Maintained Contact Controls</b> - includes one 3-button wall mount push button station, Up/Down/E-Stop (shipped loose). Price includes upper and lower limit switches.	\$560
<b>External / Remote Power Units</b> - all three-phase units include a transformer for low-voltage control, 6' of hose and a mounting stand.	\$130
<b>Optional Power Unit Upgrades</b> Convert from 1HP/115V/single phase to 1-1/2HP/230V/460V/3 phase (when selecting the 1-1/2HP 3 phase motor, please specify either a 1 GPM or 1.5 GPM pump) 3HP and 5HP motor/pump options	\$190 Call for Pricing
<b>12V DC &amp; 24V DC Power Units</b> - please specify if a power source is required. These options are available with or without a battery, battery compartment, and charger.	Call for Pricing
<b>Upper Travel Limit Switch</b> - wired & mounted (N4). Please specify maximum elevation.	\$210
<b>Lower Travel Limit Switch</b> - wired & mounted (N4). Please specify minimum lowered elevation.	\$210
<b>Velocity Fuse</b> - a safety feature to lock the unit in position in the event of a total hydraulic pressure loss. Price includes upper travel limit switch.	\$290
<b>Water Washdown Motor Package (NEMA 4)</b> - Water washdown rated 1HP motor and down valve. Includes oil-tight junction box and control panel 3HP water wash down motor available	\$610 Call for Pricing
<b>Air Power Unit</b> - air motor with hydraulic pump. 1.5 GPM at 80 PSI and 80 CFM of free air with lift fully loaded. Includes a hand or foot control valve (FRL not included) Air filter & lubricator Air limit switch (requires external power unit) mounted and plumbed	\$1020 \$400 \$760
<b>Fire-Resistant Hydraulic Fluid</b> - water-glycol fluids are fire-resistant, non-explosive and non-toxic. Approved by Factory Mutual Insurance Engineering Laboratories.	\$260
<b>Low Temp or Aircraft Grade hydraulic fluid</b>	\$170
<b>Food Grade or Biodegradable hydraulic fluid</b>	\$170

# Turntables

## Standard Turntables

Turntable Size	Shipping Weight	Price Each
<b>Standard Turntables</b>		
24 x 24"	200 lbs	\$640
24 x 36"	250 lbs	\$740
36 x 36"	300 lbs	\$830
36 x 48"	350 lbs	\$900
42 x 42"	400 lbs	\$950
42 x 48"	425 lbs	\$1,000
48 x 48"	450 lbs	\$1,030
48 x 56"	500 lbs	\$1,120



### Features

- 1/2" thick platform with radius corners, base plate, center shaft with bearing, and inverted ball roller bearing assemblies
- Standard capacity up to 6,000 lbs (uniform load)
- Standard height is 2-3/4"
- Turntables can be mounted to a lift table, floor stand, or directly to the floor.

- 180° spring position detents.....\$90
- 90° spring position detents.....\$180
- 90° positive locking positioner.....\$590
- Round turntable in place of square platform....\$150
- Other sizes available; please contact Sales
- Turret-style bearing is available for heavier loads and larger sizes; please contact Sales
- Raised floor stand/sub base available - specify desired elevation. Contact Sales.
- Powered turntables are available, standard height is 9"; contact Sales



## Presto Ring Floor-Mount Turntable

Model Number	Load Capacity	Lowered Height	Turntable Diameter	Shipping Weight	Price Each
<b>Floor-Mount Turntable</b>					
RFT	4000 lbs	7/8"	43-5/8"	70 lbs	\$670

### Features

- 2-1/8" high turntable with multiple bearings around the entire ring
- Turntable can be mounted on the floor or to any platform
- 4400 lb capacity



## Presto Low-Profile Turntable

Model Number	Load Capacity	Lowered Height	Turntable Diameter	Overall Dimensions	Shipping Weight	Price Each
<b>Low-Profile Turntable</b>						
LPT	4000 lbs	7/8"	43-5/8"	48-5/8"	250 lbs	\$1,040

### Features

- 7/8" height allows for pallet jack loading
- Outer ring notch allows for lifting the turntable off the floor for easy relocation
- No lagging required
- 4000 lb capacity



# Pneumatic Lift Tables

## Pneumatic Scissor Lifts

Model Number	Load Capacity	Raised Height	Lowered Height	Vertical Travel	Base Size W / L	Platform Size W / L	Shipping Weight	Price Each
<b>AX10 Series</b>								
AX10-3648	1000 lbs	29"	8"	21"	36 x 48"	36 x 48"	820 lbs	\$2,500
AX10-4848	1000 lbs	29"	8"	21"	36 x 48"	48 x 48"	890 lbs	\$2,580
AX10-4856	1000 lbs	29"	8"	21"	36 x 48"	48 x 56"	935 lbs	\$2,640
AX10-4860	1000 lbs	29"	8"	21"	36 x 48"	48 x 60"	960 lbs	\$2,670
<b>AX20 Series</b>								
AX20-3648	2000 lbs	32"	8"	24"	36 x 48"	36 x 48"	855 lbs	\$2,640
AX20-4848	2000 lbs	32"	8"	24"	36 x 48"	48 x 48"	915 lbs	\$2,880
AX20-4856	2000 lbs	32"	8"	24"	36 x 48"	48 x 56"	955 lbs	\$2,890
AX20-4860	2000 lbs	32"	8"	24"	36 x 48"	48 x 60"	1040 lbs	\$2,990
<b>AX40 Series</b>								
AX40-4848	4000 lbs	32"	8"	24"	48 x 48"	48 x 48"	1040 lbs	\$3,550
AX40-4856	4000 lbs	32"	8"	24"	48 x 48"	48 x 56"	1115 lbs	\$3,660
AX40-4860	4000 lbs	32"	8"	24"	48 x 48"	48 x 60"	1135 lbs	\$3,690



### Features

- 1000 - 4000 lb capacity
- 21" & 24" travel
- 8" lowered height
- 32" raised height
- Air requirements - 80 psi at 15 cfm
- Pressure relief valve standard
- Lifetime warranty on actuator
- Standard pedestal control
- Optional foot control
- Designed for stationary use and must be lagged to the floor
- Custom platforms available
- Hand control is not available on any pneumatic lift/tilts

## Heavy-Duty Pneumatic Scissor Lifts



Model Number	Load Capacity	Raised Height	Lowered Height	Vertical Travel	Base Size W / L	Platform Size W / L	Shipping Weight	Price Each
<b>AXS20 Series</b>								
AXS20-3648	2000 lbs	36"	12"	24"	36 x 48"	36 x 48"	855 lbs	\$3,730
AXS20-4848	2000 lbs	36"	12"	24"	36 x 48"	48 x 48"	915 lbs	\$3,820
AXS20-4856	2000 lbs	36"	12"	24"	36 x 48"	48 x 56"	955 lbs	\$3,960
AXS20-4860	2000 lbs	36"	12"	24"	36 x 48"	48 x 60"	1040 lbs	\$3,990
<b>AXS40 Series</b>								
AXS40-3648	4000 lbs	36"	12"	24"	36 x 48"	36 x 48"	1020 lbs	\$4,690
AXS40-4848	4000 lbs	36"	12"	24"	36 x 48"	48 x 48"	1040 lbs	\$4,750
AXS40-4856	4000 lbs	36"	12"	24"	36 x 48"	48 x 56"	1115 lbs	\$4,860
AXS40-4860	4000 lbs	36"	12"	24"	36 x 48"	48 x 60"	1135 lbs	\$4,880
<b>AXS60 Series</b>								
AXS60-4848	6000 lbs	36"	12"	24"	48 x 48"	48 x 48"	1170 lbs	\$6,590
AXS60-4856	6000 lbs	36"	12"	24"	48 x 48"	48 x 56"	1315 lbs	\$6,700
AXS60-4860	6000 lbs	36"	12"	24"	48 x 48"	48 x 60"	1335 lbs	\$6,720
<b>AXS80 Series</b>								
AXS80-4848	8000 lbs	36"	12"	24"	48 x 48"	48 x 48"	1340 lbs	\$7,190
AXS80-4856	8000 lbs	36"	12"	24"	48 x 48"	48 x 56"	1415 lbs	\$7,240
AXS80-4860	8000 lbs	36"	12"	24"	48 x 48"	48 x 60"	1435 lbs	\$7,390

### Features

- 2000 - 8000 lb capacity
- 24" travel
- 36" raised heights
- Air requirements are 80 psi at 15 cfm
- Lifetime warranty on actuator
- Pressure relief valve standard
- Standard pedestal control
- Optional foot control
- Transportable version available
- No floor lagging necessary
- Custom platforms available

Pneumatic options on page 30

# Pneumatic Lift & Tilt

## Pneumatic Scissor Lift & Tilt

Model Number	Load Capacity	Raised Height	Lowered Height	Degree of Tilt	Vertical Travel	Base Size W / L	Platform Size W / L	Shipping Weight	Price Each
<b>AXT10 Series</b>									
AXT10-3648	1000 lbs	36"	15"	30°	21"	36 x 48"	36 x 48"	1190 lbs	\$4,480
AXT10-4848	1000 lbs	36"	15"	30°	21"	36 x 48"	48 x 48"	1300 lbs	\$4,610
AXT10-4856	1000 lbs	36"	15"	30°	21"	36 x 48"	48 x 56"	1390 lbs	\$4,750
AXT10-4860	1000 lbs	36"	15"	30°	21"	36 x 48"	48 x 60"	1440 lbs	\$4,880
<b>AXT20 Series</b>									
AXT20-3648	2000 lbs	39"	15"	30°	24"	36 x 48"	36 x 48"	1365 lbs	\$4,880
AXT20-4848	2000 lbs	39"	15"	30°	24"	36 x 48"	48 x 48"	1395 lbs	\$5,010
AXT20-4856	2000 lbs	39"	15"	30°	24"	36 x 48"	48 x 56"	1450 lbs	\$5,180
AXT20-4860	2000 lbs	39"	15"	30°	24"	36 x 48"	48 x 60"	1540 lbs	\$5,380
<b>AXT40 Series</b>									
AXT40-4848	4000 lbs	39"	15"	30°	24"	48 x 48"	48 x 48"	1540 lbs	\$5,930
AXT40-4856	4000 lbs	39"	15"	30°	24"	48 x 48"	48 x 56"	1595 lbs	\$6,200
AXT40-4860	4000 lbs	39"	15"	30°	24"	48 x 48"	48 x 60"	1635 lbs	\$6,490



### Features

- 1000 - 4000 lb capacity
- 21" & 24" vertical travel
- 30° tilt
- Standard pedestal control
- Optional foot control
- Air requirements are 80 psi at 15 cfm
- Pressure relief valve standard
- Lifetime warranty on actuator
- Designed for stationary use and must be lagged to the floor
- Custom designs available
- 35° & 45° tilt available, please contact Sales

## Heavy-Duty Pneumatic Scissor Lift & Tilt



Shown with optional lip

Model Number	Load Capacity	Raised Height	Lowered Height	Degree of Tilt	Vertical Travel	Base Size W / L	Platform Size W / L	Shipping Weight	Price Each
<b>AXST20 Series</b>									
AXST20-3648	2000 lbs	43"	19"	30°	24"	36 x 48"	36 x 48"	1200 lbs	\$6,170
AXST20-4848	2000 lbs	43"	19"	30°	24"	36 x 48"	48 x 48"	1320 lbs	\$6,270
AXST20-4856	2000 lbs	43"	19"	30°	24"	36 x 48"	48 x 56"	1460 lbs	\$6,450
AXST20-4860	2000 lbs	43"	19"	30°	24"	36 x 48"	48 x 60"	1540 lbs	\$6,550
<b>AXST40 Series</b>									
AXST40-3648	4000 lbs	43"	19"	30°	24"	36 x 48"	36 x 48"	1450 lbs	\$7,160
AXST40-4848	4000 lbs	43"	19"	30°	24"	36 x 48"	48 x 48"	1570 lbs	\$7,240
AXST40-4856	4000 lbs	43"	19"	30°	24"	36 x 48"	48 x 56"	1690 lbs	\$7,290
AXST40-4860	4000 lbs	43"	19"	30°	24"	36 x 48"	48 x 60"	1770 lbs	\$7,390
<b>AXST60 Series</b>									
AXST60-4848	6000 lbs	43"	19"	30°	24"	48 x 48"	48 x 48"	1660 lbs	\$10,490
AXST60-4856	6000 lbs	43"	19"	30°	24"	48 x 48"	48 x 56"	1780 lbs	\$10,600
AXST60-4860	6000 lbs	43"	19"	30°	24"	48 x 48"	48 x 60"	1860 lbs	\$10,700
<b>AXST80 Series</b>									
AXST80-4848	8000 lbs	43"	20"	30°	23"	48 x 48"	48 x 48"	1735 lbs	\$11,690
AXST80-4856	8000 lbs	43"	20"	30°	23"	48 x 48"	48 x 56"	1850 lbs	\$11,800
AXST80-4860	8000 lbs	43"	20"	30°	23"	48 x 48"	48 x 60"	1930 lbs	\$11,910

### Features

- 2000 - 8000 lb capacity
- 24" travel
- 30° tilt
- Air requirements are 80 psi at 15 cfm
- Pressure relief valve standard
- Lifetime warranty on actuator
- Standard pedestal control
- Optional foot control
- Custom designs available
- 35° & 45° tilt available, please contact Sales

Pneumatic options on page 30

# Pneumatic Lift & Rotate

## Pneumatic Scissor Lift & Rotate



Shown with optional accordion skirting

Model Number	Load Capacity	Raised Height	Lowered Height	Vertical Travel	Base Size W / L	Platform Size W / L	Shipping Weight	Price Each
<b>AXR10 Series</b>								
AXR10-3648	1000 lbs	32"	11"	21"	36 x 48"	36 x 48"	1055 lbs	\$3,080
AXR10-4848	1000 lbs	32"	11"	21"	36 x 48"	48 x 48"	1185 lbs	\$3,290
AXR10-4856	1000 lbs	32"	11"	21"	36 x 48"	48 x 56"	1280 lbs	\$3,420
AXR10-4860	1000 lbs	32"	11"	21"	36 x 48"	48 x 60"	1320 lbs	\$3,550
<b>AXR20 Series</b>								
AXR20-3648	2000 lbs	35"	11"	24"	36 x 48"	36 x 48"	1155 lbs	\$3,600
AXR20-4848	2000 lbs	35"	11"	24"	36 x 48"	48 x 48"	1295 lbs	\$3,760
AXR20-4856	2000 lbs	35"	11"	24"	36 x 48"	48 x 56"	1385 lbs	\$3,930
AXR20-4860	2000 lbs	35"	11"	24"	36 x 48"	48 x 60"	1450 lbs	\$4,050
<b>AXR40 Series</b>								
AXR40-4848	4000 lbs	35"	11"	24"	48 x 48"	48 x 48"	1420 lbs	\$4,730
AXR40-4856	4000 lbs	35"	11"	24"	48 x 48"	48 x 56"	1550 lbs	\$4,860
AXR40-4860	4000 lbs	35"	11"	24"	48 x 48"	48 x 60"	1595 lbs	\$4,980

### Features

- 1000 - 4000 lb capacity
- 21" & 24" vertical travel
- Turntable
- Standard pedestal control
- Optional foot control
- Pressure relief valve standard
- Lifetime warranty on actuator
- Air requirements are 80 psi at 15 cfm
- Designed for stationary use
- Optional turret bearing
- Custom designs available

## Heavy-Duty Pneumatic Scissor Lift & Rotate

Model Number	Load Capacity	Raised Height	Lowered Height	Vertical Travel	Base Size W / L	Platform Size W / L	Shipping Weight	Price Each
<b>AXS20 Series</b>								
AXSR20-3648	2000 lbs	39"	15"	24"	36 x 48"	36 x 48"	1155 lbs	\$4,810
AXSR20-4848	2000 lbs	39"	15"	24"	36 x 48"	48 x 48"	1295 lbs	\$4,950
AXSR20-4856	2000 lbs	39"	15"	24"	36 x 48"	48 x 56"	1385 lbs	\$5,080
AXSR20-4860	2000 lbs	39"	15"	24"	36 x 48"	48 x 60"	1450 lbs	\$5,210
<b>AXS40 Series</b>								
AXSR40-3648	4000 lbs	39"	15"	24"	36 x 48"	36 x 48"	1370 lbs	\$5,910
AXSR40-4848	4000 lbs	39"	15"	24"	36 x 48"	48 x 48"	1420 lbs	\$6,060
AXSR40-4856	4000 lbs	39"	15"	24"	36 x 48"	48 x 56"	1550 lbs	\$6,200
AXSR40-4860	4000 lbs	39"	15"	24"	36 x 48"	48 x 60"	1595 lbs	\$6,330
<b>AXS60 Series</b>								
AXSR60-4848	6000 lbs	39"	15"	24"	48 x 48"	48 x 48"	1620 lbs	\$7,880
AXSR60-4856	6000 lbs	39"	15"	24"	48 x 48"	48 x 56"	1750 lbs	\$8,020
AXSR60-4860	6000 lbs	39"	15"	24"	48 x 48"	48 x 60"	1795 lbs	\$8,170
<b>AXS80 Series</b>								
AXSR80-4848	8000 lbs	39"	15"	24"	48 x 48"	48 x 48"	1720 lbs	\$8,680
AXSR80-4856	8000 lbs	39"	15"	24"	48 x 48"	48 x 56"	1850 lbs	\$8,810
AXSR80-4860	8000 lbs	39"	15"	24"	48 x 48"	48 x 60"	1895 lbs	\$8,970



### Features

- 2000 - 8000 lb capacity
- 24" travel
- Turntable
- Air requirements are 80 psi at 15 cfm
- Lifetime warranty on actuator
- Optional turret bearing
- Pressure relief valve standard
- Standard pedestal control
- Optional foot control
- Transportable version available
- No floor lagging necessary
- Oversized turntables available
- Custom designs available

Pneumatic options on page 30

# Pneumatic Tilt Tables

## Pneumatic Tilt Tables



Model Number	Load Capacity	Lowered Height	Base Size W / L	Platform Size W / L	Shipping Weight	Price Each
<b>AT10 Series</b>						
AT10-3648	1000 lbs	7"	36 x 48"	36 x 48"	640 lbs	\$2,080
AT10-4848	1000 lbs	7"	36 x 48"	48 x 48"	700 lbs	\$2,110
AT10-4856	1000 lbs	7"	36 x 48"	48 x 56"	750 lbs	\$2,220
AT10-4860	1000 lbs	7"	36 x 48"	48 x 60"	770 lbs	\$2,240
<b>AT20 Series</b>						
AT20-3648	2000 lbs	7"	36 x 48"	36 x 48"	690 lbs	\$2,220
AT20-4848	2000 lbs	7"	36 x 48"	48 x 48"	770 lbs	\$2,240
AT20-4856	2000 lbs	7"	36 x 48"	48 x 56"	835 lbs	\$2,350
AT20-4860	2000 lbs	7"	36 x 48"	48 x 60"	855 lbs	\$2,370
<b>AT40 Series</b>						
AT40-4848	4000 lbs	7"	36 x 48"	48 x 48"	795 lbs	\$2,370
AT40-4856	4000 lbs	7"	36 x 48"	48 x 56"	850 lbs	\$2,480
AT40-4860	4000 lbs	7"	36 x 48"	48 x 60"	880 lbs	\$2,500
<b>AT60 Series</b>						
AT60-4848	6000 lbs	7"	48 x 48"	48 x 48"	890 lbs	\$3,420
AT60-4856	6000 lbs	7"	48 x 48"	48 x 56"	970 lbs	\$3,600
AT60-4860	6000 lbs	7"	48 x 48"	48 x 60"	1040 lbs	\$3,660

### Features

- 2000 - 6000 lb capacity
- Air requirements are 80 psi at 15 cfm
- Standard pedestal control
- Foot control available
- Optional floor stand available
- Pressure relief valve standard
- Optional fork pockets
- Lifetime warranty on actuator
- Optional motion stabilizer
- Custom designs available
- Restraining chain to guard against over-tilt
- 35° & 45° tilt available, please contact Sales

# Pneumatic Options

## Mechanical Options

Description and Specification	List Price	Description and Specification	List Price
<b>Oversized Platform</b> - platforms can be increased in width and length up to an additional 24". Side and end-load capacities are de-rated 2% per inch of increase and oversized models must be lagged to the floor.	\$360	<b>Transportable Units</b> - Two rigid and two swivel casters with 6" diameter steel or texite wheels and one Presto heavy duty foot operated floor lock. This option adds between 5" and 10-1/4" to the lowered and raised elevations (depending on the positioning of the casters). <i>AXS20, AXS40, AXS60 Models with oversized platforms Tilt and Lift &amp; Tilt models Other models, please contact Sales</i>	\$760 Call for Pricing Call for Pricing
<b>Platform with Beveled Edges</b> - welded at 30° angles, beveled edges increase the standard platform by 4" on all sides.	Call for Pricing		
<b>Optional Platforms &amp; Overlay material</b> - for special handling of loads: V-cradle tops, stainless steel, diamond plate, and UHMV	Call for Pricing		
<b>Lifting Eyes</b> - provided for installation and transportation of unit with a sling or a lifting chain.	\$130	<b>Removable Push Handle</b>	\$150
<b>Accordion (Bellows) Skirts</b> - vinyl, alternating black & yellow 3" pleats. Encloses the base and leg assembly. <i>AX10, AX20, AXR10, AXR20, AXS20, AXS40, AXSR20, AXSR40 AX40, AXR40, AXS60, AXS80, AXSR60, AXSR80 AT10, AT20, AT40 AXT10, AXT20, AXST20, AXST40 AXT40, AXST60, AXST80 Other models, please contact Sales.</i>	\$550	<b>Fork Pockets</b> - 6" x 3" or 8" x 3" enclosed steel tube. Specify fork spread when consulting Sales. Adds 3" to the lowered and raised elevations when mounted under the base frame. <i>AXS Heavy Duty series lifts only Tilt and Lift &amp; Tilt models, contact Sales.</i>	Call for Pricing
	\$650	<b>Floor Stands</b> - designed to increase the lowered height of tilters. Please specify desired elevation.	Call for Pricing
	\$450		
	\$950		
	\$1,100	<b>Motion Stabilizer</b> - reduces the bounce found in pneumatic tilt tables.	Call for Pricing
<b>Portable / Semi Live Arrangement</b> - includes two fixed 5" wheels on one end/side (specify side or end mount) and a pull plate with wheeled dolly handle on the opposite end/side of the base frame. For moving lifts when empty. <i>AXS20, AXS40, AXS60 Models with oversized platforms Tilt and Lift &amp; Tilt models Other models, please contact Sales.</i>	\$470	<b>Turntable Options for AXR and AXSR series lifts</b> 180° spring position detents \$90 90° spring position detents \$180 90° positive locking positioner \$590 Turret-style bearing is available for heavier loads and larger sizes Call for Pricing	Call for Pricing
	Call for Pricing		
<b>V-Grooved Wheels</b> - 5" steel wheels for transportable units only, sold per pair.	Call for Pricing	<b>Foot Controlled Pneumatic Valve (in place of standard pedestal mounted valve)</b> AT, AX, AXR, AXS, & AXSR series AXT and AXST Dual Foot Controls	No Charge \$180

# Skid Lifters

## Skid Lifters



Model Number	Load Capacity	Raised Height	Lowered Height	Unit O.D.	Fork Length	Shipping Weight	Price Each
<b>PSL Series - Manual Lift</b>							
PSL-25/20-M	2500 lbs	32"	3-1/2"	21-1/4"	45"	244 lbs	\$850
PSL-25/27-M	2500 lbs	32"	3-1/2"	27"	45"	244 lbs	\$850
PSL-30/20-M	3000 lbs	32"	3-1/2"	21-1/4"	45"	244 lbs	\$1,130
PSL-30/27-M	3000 lbs	32"	3-1/2"	27"	45"	244 lbs	\$1,130
<b>PSL Series - Electric Lift</b>							
PSL-22/20-E	2200 lbs	31-1/2"	3-1/2"	21-1/4"	44"	375 lbs	\$2,140
PSL-22/27-E	2200 lbs	31-1/2"	3-1/2"	27"	44"	375 lbs	\$2,140

These versatile skid positioners are ideal for feeding conveyors, steel punch, or print presses. All models feature a 180° steering arc and ergonomically designed handle. Choose from either the manual hand pump or the battery powered lift model.  
*For use with open bottom skids or pallets only.*

### Features

#### Manual Skid Lifter Features

- 2500 or 3000 lb capacity
- Quick lift, 30 strokes for loads less than 600 lbs
- 60 strokes for heavier loads

#### Battery Powered Skid Lifter Features

- 2200 lb capacity
- 12VDC (70Ah) battery with built-in 110V 15A charger

# Pallet Trucks

## HPT Series Hand Pallet Trucks



Model Number	Load Capacity	Raised Height	Lowered Height	Overall Width	Fork Length	Fork Width	Shipping Weight	Price Each
<b>HPT Series</b>								
HPT55-2748	5500 lbs	7-5/8"	2-7/8"	27"	48"	7"	170 lbs	\$430
HPT55-2148	5500 lbs	7-5/8"	2-7/8"	21-1/4"	48"	7"	170 lbs	\$430

### Features

- Powder coated paint finish
- Solid steel formed forks and chassis with reinforced frame and gusset
- Highest quality pump with special lowering valves and an overload by-pass
- 7" x 2" nylon steer wheels
- 2-7/8" x 3-1/2" nylon load wheels
- All pivot points come with sealed bearings
- 9 strokes to full raised height
- Fork-tip roller system for smooth transition in and out of pallets
- Articulating steer axle
- Ergonomic cushioned handle with 3 function trigger for raise, lower, and neutral operation
- Galvanized and Stainless Steel models are available, please contact Sales

Highlighted models are AIS (Always In Stock) and ship within one week.



# Select a Stacker

## Guidelines for Stackers

### What Lift Height is required?

Fixed-mast units range from 50"-86". Telescopic (2 stage) mast units range from 94"-144".

### What is the weight of the heaviest load?

1000, 1500, 2000, 2700, and 3000 lb capacities are available. Take into consideration the added weight of the pallet or container.

### What is the length (front to back) of the load?

Load center capacity is as important as weight capacity (see separate load center (LC) diagram below).

- 48" long pallets require 24" LC
- 40" long pallets require 20" LC

The length of the load must not be longer than twice the size of the rated load center.

### What type of lifting power is needed?

Manually operated lifts should be selected for lighter weights and work cycles.

Electric (AC or DC) lifts should be selected for heavier weights and work cycles.

### What is the maximum overall height allowed?

Overall height is 14"-18" higher than the lifting height of the unit. Take into consideration doorways, pipes, lighting, and overhead obstructions.

### What are the width restrictions?

Check the width of all doorways, narrow aisles or congested areas to be navigated. Take into consideration the width of the unit with and without a load.

### What type of load is being lifted?

Would special attachments help? Ram, boom with hook, remote control, special forks, or platforms are available. See the options and attachments on page 11.

### Platform Models

Platform models are used as portable lift tables in numerous ergonomic applications. Oversized platforms are available on special orders.

### Non-Straddle Fork Models

Non-straddle fork models have base legs closer together. Normally used for skids where wheels and base legs, as well as the forks, go under the skid.

### Straddle Fork Models

Straddle fork models have wider base legs, or out-riggers, which straddle the load or pallet. For example, a 50" I.D. on straddle legs would be required for a 48" wide pallet.

### Custom Applications

Many standard lifts can be modified for special lifting tasks. Please contact our Sales department.

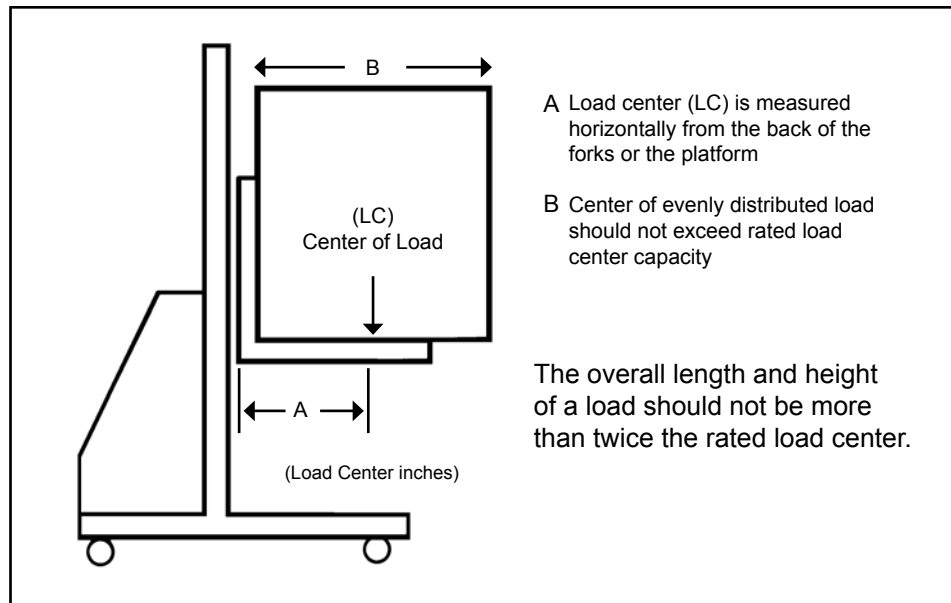

# Select a Scissor Lift

## Guidelines for Scissor Lifts

### Vertical Travel

Determine the maximum raised height requirements to select the vertical travel of a unit.

### Load Capacity and Side/End Loading Capacities

Load capacity is the amount of weight of an evenly balanced and centered load. Side/End capacity is the weight of the load over the edge when the lift is in a fully raised position (often less than the balanced load capacity).

### Power Supply

Single-phase 1 HP motor or three-phase 1-1/2 HP motor is standard as shown (not available on XS series units).

Upon request, motors can be interchanged.

External, remote, and air motors are also available, please contact Sales.

### Frequency and Speed of Operation

The standard motor is rated for intermittent duty. If usage is more than one full lift every four minutes, or jogging action every 10 seconds, the motor will overheat. Optional external power units are available, as well as for increased lifting speed.

### Lowered Height

For a lower than standard height, pit-mounted units (ground level) are available.

Pit mounted units must have beveled platform edges or electromechanical toe guards to conform to OSHA recommendations.

Toe guards extend the length and the width of a standard platform by 8".

Lifting eyes are also required for installation.

### Platforms

Standard platform sizes conform to standard base sizes.

Platform sizes may be widened and/or lengthened up to an additional 24".

Platforms with beveled edges increase the standard platform size by 4" on each side.

Side/End capacity is derated by 2% per inch on all oversized platforms.

### Portability

Portability packages are used to move empty lifts. They include 2 steel wheels, side or end mounted, with a wheeled dolly. Please contact Sales if you are looking to add a portability package to a unit with an oversized platform.

Transportability packages are used to move lifts carrying a load. They include 2 fixed and 2 swivel casters.

### Electric Controls

Push-button, hand-held controls (NEMA 12) with an 8' cord is standard.

Optional foot-operated up/down controls with safety covers, wall-mounted controls (NEMA 4), and pedestal mounted controls with a NEMA 12 push-button enclosure are available. Please contact Sales.

### Other Options

- Stainless steel skin or diamond plate top material
- Conveyor tops
- Turntables
- Ball transfer platforms
- Accordion (bellows) skirts
- Non-flammable and low temperature hydraulic fluid
- Wash down units
- Adjustable flow control valves
- Fork pockets

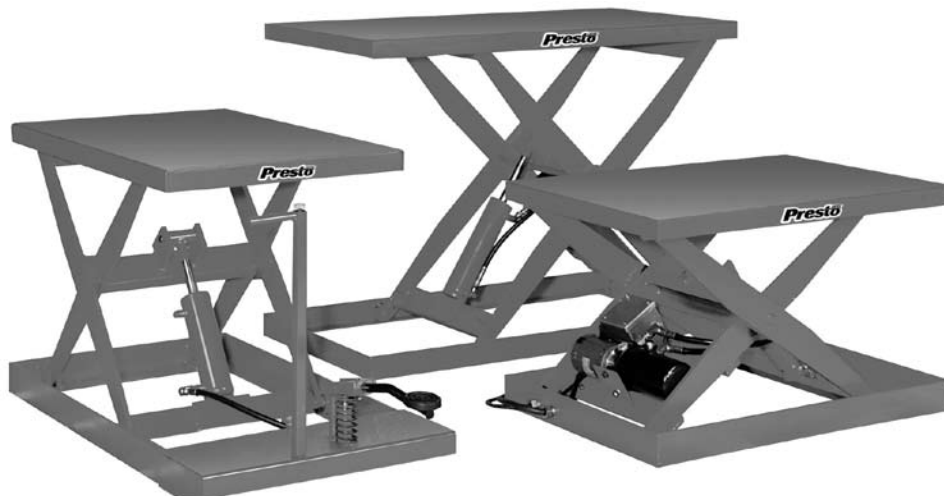

# Select a Tilt Table

## Guidelines for Tilt Tables

### Loads Being Tilted

Determine all types of loads that might be tilted, i.e. boxes, pallets, wire baskets, crated, corrugated steel, wire-bound wood boxes, etc. to ensure selection of the correct model.

### Load Capacity

Take into consideration the weight of the container and its contents, as well as off-centered and shifting loads.

### Degree of Tilt

Determine the degree of tilt needed: 30°, 45°, 60°, and 90°. All 60° and 90° tilt tables must be lagged down to the floor.

### Platform Size

Standard platform sizes conform to standard base sizes. Platform sizes can be widened and lengthened. Determine the width, length (depth), and height of the load being tilted.

Standard lip size is 8". Optional oversized lips are available for larger loads (containers). Gussets (1 or 2) for squaring the load (centering) are also available.

### Orientation of Tilt

Determine which side the unit will tilt on. A platform size of 36" x 48" can be tilted on either side, depending on the application.

### Type of Mount

Units can be floor-mounted, stand-mounted, or scissor lift-mounted (for vertical lift and tilt). All tilt applications must be lagged to the floor. Lift and tilt applications require tilt tables to be mounted on the roller end of the scissor lifts. Please contact Sales.

### Controls

Hand-held, push-button up/down controls are standard on all tilt tables. Standard and wide-base tilt tables can interchange a foot control. Lightweight tilt tables have an option for a foot control. Lift and tilt applications require two (2) separate controls.

### Power Supply

Standard and wide base tilt tables have 115/1/60 1 HP motors. There is an option for 230, 460/3/60 1-1/2 HP motors. Lightweight tilt tables have 115/1/60 1/3 HP motors only. Lift and tilt applications operate on two (2) separate power units, unless otherwise specified.

The pneumatic power supply assembly includes a refillable chamber that has an interior capable of holding pressurized fluid, a vent, and a fluid inlet. A pressure release mechanism within the chamber permits the pressure within the chamber to vent when the pressure exceeds a predetermined optimum pressure. Pneumatic power is completely operated on plant air and is EPA friendly.

### Standard and Wide-Base Tilter Options

- Oversized lip up to 24" (contact Sales for lips over 24").
- Gussets (reinforcing sides, lip and/or platform).
- Oversized platform (wider and longer) in 6" increments.
- Floor stand - standard height is 12". Custom sizes available.
- Fork pockets (not available for all units).
- 3-phase 1-1/2" motor (208, 230, 460/3/60). Not available for light-weight models.
- External, larger motors are available on some models. Please contact Sales.
- Accordion (bellows) skirting.
- Pit-mounted units require a beveled edge platform or electromechanical toe guards. Please contact Sales.
- Portability and transportability packages available on some models.



## Limited Warranty Policy

Presto Lifts warrants all of its products (excluding PowerStak) against defects in the welded structural frame and, if applicable, scissor legs from faulty material and workmanship for a period of five years from the date of invoice.

A lifetime limited warranty is provided for the Airstroke Actuator™ in all pneumatic lifts against any defect due to faulty material or workmanship. All batteries are covered under a separate limited warranty from the battery manufacturer for a period of one year from the date of invoice. All other components have a limited warranty against defects in faulty material and workmanship for a two year period from the date of invoice and 30 day limited warranty on labor. Please note that prior authorization from Presto Lifts is required on all warranty work.

There are no implied warranties of any kind, more specifically, there are no warranties of merchantability or fitness for any particular purpose. Presto Lifts' sole warranty shall be as set forth in this limited warranty.

Presto Lifts will elect to repair or replace a defective component without charge, if any components should become defective within the limited warranty period. Proof of purchase is required for warranty. The charge for shipping the defective component is the responsibility of the buyer and must be accompanied with an RGA number. The shipping charge to return the component to the buyer is the responsibility of Presto Lifts, Inc. This limited warranty does not cover labor expense for removal or reinstallation of components after thirty days.

This limited warranty shall not cover, among other things: damages resulting from foreign matter or water, failure to provide reasonable and necessary maintenance, and if applicable, use of product while charger is plugged into an AC outlet, or failure to follow operating instructions. The limited warranty is not valid for damage resulting from negligence, accident, unreasonable use, abuse, or misuse, exceeding data plate capacities or

altering the product without Presto Lifts authorization. Presto Lifts expressly disclaims and excludes any liability for consequential, incidental, indirect or punitive damages or financial loss to people or property resulting from any breach of warranty or the operation or failure of this product.

Presto Lifts makes no representation that this product complies with local, state, or federal safety/product standards codes. Should this product fail to comply in any way with those codes, it shall not be considered a defect of materials or workmanship. Presto Lifts shall not be held liable for any damages resulting from noncompliance. It is the dealer's responsibility to exercise this limited warranty. This limited warranty is provided to the original purchaser (defined as the original end user) and is nontransferable. This constitutes the complete and final agreement involving Presto Lifts and limited warranty obligations for products.

## PowerStak Warranty Policy

Presto Lifts warrants the PowerStak against defects in the welded structural frame and AC motors on lifts equipped with an AC power unit from faulty material and workmanship for a period of two (2) years from the date of invoice.

Presto Lifts warrants the PowerStak against defects in the mast, fork carriage, chains, pumps, DC motors, controllers, cylinders, and wiring harnesses from faulty material and workmanship for a period of one (1) year from the date of invoice.

All wear items such as batteries, wheels, motor brushes, seals, bearings, hydraulic hoses, all switches, battery chargers, and forks have a limited warranty against defects in faulty material and workmanship for a ninety (90) day period from the date of invoice and a thirty (30) day limited warranty on labor. Please note that prior authorization from Presto Lifts is required for all warranty work.

# PRESTO LIFTS INQUIRY FORM

Coordinator: \_\_\_\_\_ Date: \_\_\_\_\_  
Distributor: \_\_\_\_\_ Salesperson: \_\_\_\_\_  
End User: \_\_\_\_\_ Type of Industry: \_\_\_\_\_  
Contact Name: \_\_\_\_\_ Phone or E-mail: \_\_\_\_\_

**A  
P  
P  
L  
I  
C  
A  
T  
I  
O  
N**

HOW IS  
LIFT  
USED?

PRODUCT BEING HANDLED: \_\_\_\_\_

WIDTH: \_\_\_\_\_ LENGTH: \_\_\_\_\_ HEIGHT: \_\_\_\_\_ WEIGHT: \_\_\_\_\_

**Requested Specifications**

PLATFORM SIZE: \_\_\_\_\_ TRAVEL TIME UP: \_\_\_\_\_ DOWN: \_\_\_\_\_

LOWERED HEIGHT: \_\_\_\_\_ VERTICAL TRAVEL: \_\_\_\_\_ RAISED HEIGHT: \_\_\_\_\_

HOW IS LIFT LOADED? \_\_\_\_\_  OVER  END  SIDE  RAISED or  LOWERED

HOW OFF LOADED? \_\_\_\_\_  OVER  END  SIDE  RAISED or  LOWERED

IS LIFT LOADED EVENLY?  YES  NO -- Then How? \_\_\_\_\_

**JOGS PER CYCLE**

**CYCLES PER HOUR**

**HOURS PER DAY**

**DAYS PER WEEK**

**ANNUAL**

FLOOR MOUNT

PIT MOUNT (Beveled Toe Guards Necessary)

TAPESWITCH

BEVEL TOE GUARD (Requires Oversize Platform)

BELLOWS SKIRTING (Requires Oversize Platform)

PORTABLE -- How? \_\_\_\_\_

OTHER: \_\_\_\_\_

SMOOTH DECK  DIAMOND TREAD

HANDRAILS -- Where? \_\_\_\_\_

TURNTABLE -- Size?

TILT TOP? DEGREES  30  45  90

OTHER: \_\_\_\_\_

**P  
O  
W  
E  
R  
E  
T  
C**

POWER UNIT:  INTERNAL  EXTERNAL  NONE

PRIMARY VOLTAGE:  115/1/60  230-460/3/60 (CHECK ONE)

CONTROLS:  PUSHBUTTON  FOOTSWITCH  NONE

MOTOR STARTER / TRANSFORMER (For 3 Phase)  NONE

LIMIT SWITCH:  UP  DOWN

NEMA CLASSIFICATION: \_\_\_\_\_

INQUIRY QUANTITY: \_\_\_\_\_

INQUIRY TYPE:  BUDGET  CURRENT CONSIDERATION

IMMEDIATE PURCHASE -- EXPECTED ORDER DATE: \_\_\_\_\_

DELIVERY REQUIREMENT: \_\_\_\_\_

COMPETITION -- WHO? \_\_\_\_\_

OTHER SALES INFORMATION: \_\_\_\_\_

PRICING: